

MOVING YOU FURTHER

# HX220 L/NL

With Tier 4 final / Stage IV Engine installed



\*Photo may include optional equipment.

**Net Power**

SAE J1349 / 129 kW (173 HP) at 1,950 rpm

**Gross Power**

SAE J1995 / 136 kW (182.6 HP) at 1,950 rpm

**Travel Speed**

5.5 km/hr (3.41 mph) /  
3.6 km/hr (2.23 mph)

**Operating Weight**

HX220 L : 22,100 kg / 48,720 lb  
HX220 NL : 22,300 kg / 49,720 lb





## RULE THE GROUND

The HX Series excavators are products of HHI's spirit of initiative, creativity and strong drive. HHI's engineers, who are the best in the industry, have worked tirelessly to offer a zero-defect product. The new HX Series reflects customers' needs in the field gleaned by thorough monitoring. They maximize fuel efficiency and performance proven by rigorous field tests and quality control.



\*Photo may include optional equipment.



# RULE THE GROUND

The HX series exceeds customers' expectation!  
Become a true leader on the ground with HHI's HX series.

# HX220 L/NL



## WORK MAX, WORTH MAX

- ECO Gauge
- IPC (Intelligent Power Control)
- New Variable Power Control
- Electronic Viscous Fan Clutch
- Attachment Flow Control (Option)
- New Cooling System with Increased Air Flow
- Enlarged Air Inlet with Grill Cover
- One Pedal Travel Straight (Option)
- Cycle Time Improvement
- Boom Floating Control (Option / HX220 L only)



## MORE RELIABLE, MORE SUSTAINABLE

- Durable Cooling Module
- Reinforced Pin, Bush and Polymer Shim
- Reinforced Durability of Upper and Lower Structure and Attachments
- Wear Resistant Cover Plate
- Hi-grade (High-pressure) Hoses



## INFOTAINMENT FRONTIER

- Intelligent and Wide Cluster
- Haptic Control
- Wi-Fi Direct with Smart Phone (Miracast)
- Proportional Auxiliary Hydraulic System
- New Audio System
- New Air Conditioning System



## MODERN COMFORT, SIMPLE AND SAFE SOLUTION

- AAVM (Advanced Around View Monitoring) Camera System (Option)
- Easy Access to DEF/AdBlue® Supply System
- Hi MATE (Remote Management System)
- Cab Suspension Mount
- Swing Lock System (Option)
- Fine Swing Control (Option)



\*Photo may include optional equipment.





\*Photo may include optional equipment.

### Cycle Time Improvement

The HX Series provides higher productivity on the site by faster operation: it loads trucks up to 5% faster and levels up to 4% faster than the 9 Series.

### Boom Floating Control (Option / HX220 L only)

This option allows for improved stability and control when leveling. The boom is allowed to float with the arm-in and arm-out movement.

# WORK MAX, WORTH MAX

## Fuel Efficient System, Allows Great Performance

The HX Series has an eco-friendly, high-performance engine which ensures both excellent fuel efficiency and high power. With outstanding operating performance proven by rigorous tests at various work sites, it will satisfy any customer's needs.



### ECO Gauge

ECO Gauge enable economic operation of machines. The gauge level and color displays engine torque and fuel efficiency level. On top of that, the status of fuel consumption such as average rate and the total amount of fuel consumed are displayed. Hourly and daily based fuel consumption can be checked in the detailed menu as well.



### IPC (Intelligent Power Control)

The IPC controls power control depending on work environments. Its mode can be selected and released on the monitor. On the excavation mode, pump flow can be easily controlled by a lever, reducing fuel consumption.

### New Variable Power Control

The HX Series minimizes equipment input and output control signals to improve fuel efficiency. Its three-stage Power mode ensures the highest performance in any operating environment.

\* P (power) mode: Maximizes speed and power of the equipment for heavy load work.

\* S (standard) mode: Optimizes performance and fuel efficiency of the equipment for general load work.

\* E (economy) mode: Improves the control system for light load work.

### Electronic Viscous Fan Clutch

The electronic fan clutch reduces noise during operation by precisely controlling RPM depending on the hydraulic oil and coolant temperature of the working vehicle, and minimizes fuel consumption. It is also possible to shorten the warm up time of hydraulic oil.



### Attachment Flow Control (Option)

The HX Series improves pump flow rate by independent control of two pumps. It optimizes attachments for effective flow rate setting depending on attachments (ten breaker types and ten crusher types), enabling various operations matching the site environments.



### Enlarged Air Inlet with Grill Cover

Enlarged vent hole of the air inlet side cover and fine net grill to prevent penetration of foreign materials further improve durability.

### One Pedal Travel Straight (Option)

One Pedal Travel Straight (Option) is available for customers' convenience when long distance traveling or combination of attachment work with traveling is necessary.

### New Cooling System with Increased Air Flow

With the three-floor stacked cooling module improving air inflow, the HX Series provides excellent cooling performance by increasing heat dissipation and can be easily cleaned.



# MORE RELIABLE, MORE SUSTAINABLE

## New Exterior Design for Robustness and Safety

The true value of the HX Series lies in its durability. The robust upper and lower frame structure that can endure external shock and high-load work and the attachments whose performance was proven by rigorous tests further show the real value of the HX Series in tough working environments and promise higher productivity.



### Durable Cooling Module

The HX Series has a durable cooling module that passed stringent tests, demonstrating the highest productivity in tough working environments.

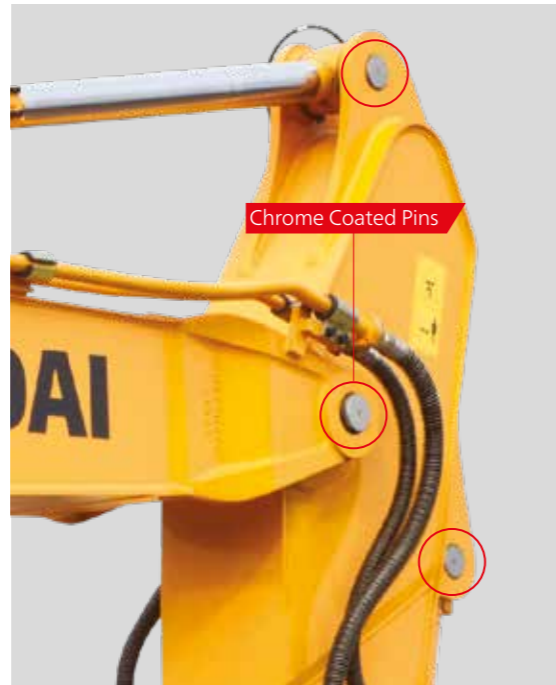

Chrome Coated Pins



### Reinforced Durability of Upper and Lower Structure and Attachments

The upper and lower structure and attachments of the HX Series have higher durability than demanded on the site, as proven through numerous tests including road tests and virtual simulation. The wear resistance of the bucket has been improved by use of new material.

### Reinforced Pin, Bush and Polymer Shim

The HX series improves lubricity of connecting parts between the equipment and attachments. Gaps with attachments are minimized by wear-resistant long-life pins, bushes and polymer shims, supporting the highest performance with invariable durability.

### Wear Resistant Cover Plate

A wear-resistant cover plate is installed at the end of the arm to minimize abrasion on the connector between the arm and the bucket. Reduction of vibration of the buckets enables more stable operation even in high-load work.



\*Photo may include optional equipment

### Hi-grade (High-pressure) Hoses

The HX Series uses high-pressure hoses with improved heat and pressure resistance, greatly increasing the durability of the equipment.





### New Air Conditioning System

With further improved air conditioning and heating, the HX Series increases the APTC capacity by 15% to provide a pleasant environment for operators all the time. The ventilation was designed such that warm and cool air even reach operators' faces (increasing their work satisfaction) or allowing pleasant working environment.

# INFOTAINMENT FRONTIER

## Enhanced Instrument Panel for Easier Monitoring

Many electronic functions are concentrated on the most convenient spot for operators to ensure work efficiency. The highly-advanced infotainment system, a product of HHI's intensive information technology, enables both productivity and pleasant work at the same time! The HX Series of HHI provides higher value and pleasure to customers.



### Intelligent and Wide Cluster

The 8-inch capacitive-type display (like smartphone display) of the HX Series is 30% larger than the previous model, delivering excellent legibility. The centralized switches on the display allow convenience of checking the urea level and temperature outside the cabin. The audio AUX, air conditioner and heater interoperation, and inclination sensor also maximize operator's convenience.



### Haptic Control

The integrated jog shuttle-type haptic controller applies to the accelerator, remote air conditioner controller and operation of the cluster, allowing convenient operation. In the event of failure of the haptic switch, the emergency mode is activated on the cluster to ensure fail-safe function.

### Wi-Fi Direct with Smart Phone (Miracast)

The Miracast system based on Wi-Fi of the operator's smart phone enables easy and convenient use of various features of the smart phone on the big screen including navigation, web surfing, viewing of videos, and listening to music. (For Android mobile phone now)



### New Audio System

Radio player, USB-based MP3 player, integrated Bluetooth hands-free feature, and built-in microphone allow convenient phone calls while in work and in transit. The radio player was moved to the right side from the rear, allowing easier access.

### Proportional Auxiliary Hydraulic System

- Opt: Proportional control switch for better speed control
- Enlarge the operation convenience



# MODERN COMFORT, SIMPLE AND SAFE SOLUTION

## New Cabin for More Comfort

Low noise, low vibration, and ergonomic design make the cabin space more comfortable and pleasant! With focus on safety and convenience of operators, the HX Series allows rapid and safe equipment inspection anytime and anywhere, providing an optimal environment for operators to work.



### AAVM (Advanced Around View Monitoring) Camera System (Option)

The HX Series has a state-of-the-art AAVM video camera system to secure field of vision for operators in all directions, thereby preventing accidents. Operators can easily check the workplace in the front, rear and to the right and left.



\* AAVM (Advanced Around View Monitoring): Secure field of vision in all directions by nine views including 3D bird's eye view and 2D/4CH view.

\* IMOD (Intelligent Moving Object Detection): Inform when people or dangerous objects are detected within the range of operation (recognition distance: 5 m).



### Easy Access to DEF/AdBlue® Supply System

The DEF/AdBlue® tank is installed inside the tool box and its inlet is remotely located for easy access and convenient supply. Warning of overfill is given by a red lamp signal. The DEF/AdBlue® supply module is attached on the side of the fuel tank for easy maintenance and filter replacement.



### Hi MATE (Remote Management System)

Hi MATE, Hyundai's proprietary remote management system, provides operators and dealer service personnel access to vital service and diagnostic information on the machine from any computer with internet access. Users can pinpoint machine location using digital mapping and set machine work boundaries, reducing the need for multiple service calls. Hi MATE saves time and money for the owner and dealer by promoting preventative maintenance and reducing machine downtime.

\* Operation of the system may be affected by the condition of telecommunication signal



\*Photo may include optional equipment.

### Swing Lock System (Option)

Swing Lock System is provided to maintain stability when swing movement needs to be limited, improving operating speed and productivity.

### Fine Swing Control (Option)

Fine swing control is available for customer's convenience when users want to control fine swing.



# SPECIFICATIONS

## HX220 L

ENGINE			
Maker / Model	Cummins QSB6.7		
Type	4-cycle turbocharged, charge air cooled diesel engine		
Rated flywheel horse power	SAE	J1995 (gross)	136 kW (182.6 HP) at 1,950 rpm
		J1349 (net)	129 kW (173 HP) at 1,950 rpm
	DIN	6271/1 (gross)	136 kW (185 PS) at 1,950 rpm
		6271/1 (net)	129 kW (175 PS) at 1,950 rpm
Max. torque	85.7 kgf-m (620 lbf-ft) at 1,500 rpm		
Bore x stroke	107 x 124 mm (4.21" x 4.88")		
Piston displacement	6,700 cc (409 cu in)		
Batteries	2 x 12 V x 100 Ah		
Starting motor	Denso 24 V - 4.8 kW		
Alternator	Denso 24 V - 95 A		

## HYDRAULIC SYSTEM

MAIN PUMP	
Type	Variable displacement tandem axis piston pumps
Max. flow	2 x 222 l/min
Sub-pump for pilot circuit	Gear pump

Cross-sensing and fuel saving pump system

## HYDRAULIC MOTORS

Travel	Two speed axial pistons motor with brake valve and parking brake
Swing	Axial piston motor with automatic brake

## RELIEF VALVE SETTING

Implement circuits	350 kgf/cm <sup>2</sup> (4,980 psi)
Travel	350 kgf/cm <sup>2</sup> (4,980 psi)
Power boost (boom, arm, bucket)	380 kgf/cm <sup>2</sup> (5,400 psi)
Swing circuit	265 kgf/cm <sup>2</sup> (3,770 psi)
Pilot circuit	40 kgf/cm <sup>2</sup> (570 psi)
Service valve	Installed

## HYDRAULIC CYLINDERS

No. of cylinder bore x stroke	Boom: Ø 120 x 1,290 mm
	2-Piece Boom: Ø 160 x 1,060 mm
	Arm: Ø 140 x 1,510 mm
	Bucket: Ø 120 x 1,055 mm

## DRIVES & BRAKES

Drive method	Fully hydrostatic type
Drive motor	Axial piston motor, in-shoe design
Reduction system	Planetary reduction gear
Max. drawbar pull	20,200 kgf (44,530 lbf)
Max. travel speed (high / low)	5.5 km/hr (3.41 mph) / 3.6 km/hr (2.23 mph)
Gradeability	35° (70%)
Parking brake	Multi wet disc

## CONTROL

Pilot pressure operated joysticks and pedals with detachable lever provide almost effortless and fatigueless operation.

Pilot control	Two joysticks with one safety lever (LH): Swing and arm (RH): Boom and bucket (ISO)
Traveling and steering	Two levers with pedals
Engine throttle	Electric, Dial type

## SWING SYSTEM

Swing motor	Fixed displacement axial piston motor
Swing reduction	Planetary gear reduction
Swing bearing lubrication	Grease-bathed
Swing brake	Multi wet disc
Swing speed	10.8 rpm

## SERVICE REFILL CAPACITIES

	liter	US gal	UK gal
Re-filling			
Fuel tank	400	106	88
Engine coolant	40	10.6	8.8
Engine oil	23	6.1	5.06
Swing device	6.2	1.64	1.36
Final drive (each)	4.5	1.2	1
Hydraulic system (including tank)	275	72.6	60.5
Hydraulic tank	160	42.3	35.2
DEF/AdBlue®	27	7.1	5.9

## UNDERCARRIAGE

The X-leg type center frame is integrally welded with reinforced box-section track frames. The undercarriage includes lubricated rollers, idlers, track adjusters with shock absorbing springs and sprockets and a track chain with double or triple grouser shoes.

Center frame	X - leg type
Track frame	Pentagonal box type
No. of shoes on each side	49 EA
No. of carrier roller on each side	2 EA
No. of track roller on each side	9 EA
No. of rail guard on each side	2 EA

## OPERATING WEIGHT (APPROXIMATE)

Operating weight, including 5,680 mm (18' 8") boom; 2,920 mm (9' 7") arm; SAE heaped 0.92 m<sup>3</sup> (1.20 yd<sup>3</sup>) bucket, lubricant, coolant, full fuel tank, full hydraulic tank and all standard equipments.

## OPERATING WEIGHT

Shoes	Operating weight		Ground pressure	
	Width mm (in)	kg (lb)		kgf / cm <sup>2</sup> (psi)
Triple grouser	600 (24")	HX220 L	22,100 (48,720)	0.47 (6.68)
		HX220 L HW	23,560 (51,940)	0.50 (7.11)
	700 (28")	HX220 L	22,380 (49,340)	0.41 (5.83)
		HX220 L HW	23,840 (52,560)	0.44 (6.26)
	800 (32")	HX220 L	22,660 (49,960)	0.36 (5.12)
		HX220 L HW	24,120 (53,170)	0.39 (5.55)
900 (36")	HX220 L	22,940 (50,570)	0.33 (4.69)	
	HX220 L HW	24,400 (53,790)	0.35 (4.98)	
Double grouser	600 (24")	HX220 L HW	23,690 (52,230)	0.50 (7.11)
	700 (28")	HX220 L HW	24,040 (53,000)	0.43 (6.11)

# SPECIFICATIONS

## HX220 NL

ENGINE			
Maker / Model	Cummins QSB6.7		
Type	4-cycle turbocharged, charge air cooled diesel engine		
Rated flywheel horse power	SAE	J1995 (gross)	136 kW (182.6 HP) at 1,950 rpm
		J1349 (net)	129 kW (173 HP) at 1,950 rpm
	DIN	6271/1 (gross)	136 kW (185 PS) at 1,950 rpm
		6271/1 (net)	129 kW (175 PS) at 1,950 rpm
Max. torque	85.7 kgf-m (620 lbf-ft) at 1,500 rpm		
Bore x stroke	107 x 124 mm (4.21" x 4.88")		
Piston displacement	6,700 cc (409 cu in)		
Batteries	2 x 12 V x 100 Ah		
Starting motor	Denso 24 V - 4.8 kW		
Alternator	Denso 24 V - 95 A		

## HYDRAULIC SYSTEM

MAIN PUMP	
Type	Variable displacement tandem axis piston pumps
Max. flow	2 x 222 l/min
Sub-pump for pilot circuit	Gear pump

Cross-sensing and fuel saving pump system

## HYDRAULIC MOTORS

Travel	Two speed axial pistons motor with brake valve and parking brake
Swing	Axial piston motor with automatic brake

## RELIEF VALVE SETTING

Implement circuits	350 kgf/cm <sup>2</sup> (4,980 psi)
Travel	350 kgf/cm <sup>2</sup> (4,980 psi)
Power boost (boom, arm, bucket)	380 kgf/cm <sup>2</sup> (5,400 psi)
Swing circuit	265 kgf/cm <sup>2</sup> (3,770 psi)
Pilot circuit	40 kgf/cm <sup>2</sup> (570 psi)
Service valve	Installed

## HYDRAULIC CYLINDERS

No. of cylinder bore x stroke	Boom: Ø 120 x 1,290 mm
	2-Piece Boom: Ø 160 x 1,060 mm
	Arm: Ø 140 x 1,510 mm
	Bucket: Ø 120 x 1,055 mm

## DRIVES & BRAKES

Drive method	Fully hydrostatic type
Drive motor	Axial piston motor, in-shoe design
Reduction system	Planetary reduction gear
Max. drawbar pull	20,200 kgf (44,530 lbf)
Max. travel speed (high / low)	5.5 km/hr (3.41 mph) / 3.6 km/hr (2.23 mph)
Gradeability	35° (70%)
Parking brake	Multi wet disc

## CONTROL

Pilot pressure operated joysticks and pedals with detachable lever provide almost effortless and fatigueless operation.

Pilot control	Two joysticks with one safety lever (LH): Swing and arm (RH): Boom and bucket (ISO)
Traveling and steering	Two levers with pedals
Engine throttle	Electric, Dial type

## SWING SYSTEM

Swing motor	Fixed displacement axial piston motor
Swing reduction	Planetary gear reduction
Swing bearing lubrication	Grease-bathed
Swing brake	Multi wet disc
Swing speed	10.8 rpm

## SERVICE REFILL CAPACITIES

	liter	US gal	UK gal
Re-filling			
Fuel tank	310	81.9	68.2
Engine coolant	40	10.6	8.8
Engine oil	23.7	6.3	5.2
Swing device	6.2	1.64	1.36
Final drive (each)	4.5	1.2	1
Hydraulic system (including tank)	340	89.8	74.8
Hydraulic tank	165	43.6	36.3
DEF/AdBlue®	27	7.1	5.9

## UNDERCARRIAGE

The X-leg type center frame is integrally welded with reinforced box-section track frames. The undercarriage includes lubricated rollers, idlers, track adjusters with shock absorbing springs and sprockets and a track chain with double or triple grouser shoes.

Center frame	X - leg type
Track frame	Pentagonal box type
No. of shoes on each side	49 EA
No. of carrier roller on each side	2 EA
No. of track roller on each side	9 EA
No. of rail guard on each side	2 EA

## OPERATING WEIGHT (APPROXIMATE)

Operating weight, including 5,650 mm (18' 6") boom; 2,920 mm (9' 7") arm; SAE heaped 0.87 m<sup>3</sup> (1.14 yd<sup>3</sup>) bucket, lubricant, coolant, full fuel tank, full hydraulic tank and all standard equipments.

## OPERATING WEIGHT

Shoes	Operating weight		Ground pressure	
	Width mm (in)	kg (lb)		kgf / cm <sup>2</sup> (psi)
Triple grouser	500 (20")	HX220 NL	22,300 (49,160)	0.57 (8.11)
	600 (24")	HX220 NL	22,400 (49,380)	0.48 (6.83)
	700 (28")	HX220 NL	22,870 (50,420)	0.42 (5.97)



# BUCKET SELECTION GUIDE & DIGGING FORCE

## HX220 L

### BUCKETS



SAE heaped m <sup>3</sup> (yd <sup>3</sup> )	0.80 (1.05) 0.92 (1.20) 1.10 (1.44) 1.20 (1.57)	1.34 (1.75)	◆ 0.90 (1.18) ◆ 1.05 (1.37)	◆ 0.87 (1.14)	◆ 1.20 (1.57)	★ 0.52 (0.68)
---	--	-------------	--------------------------------	---------------	---------------	---------------

Capacity m <sup>3</sup> (yd <sup>3</sup> )	Width mm (in)	Weight kg (lb)	Recommendation mm (ft.in)									
			5,680 (18' 8") Boom				5,650 (18' 6") 2-Piece Boom			8,200 (26' 11") Boom		
			2,000 (6' 7") Arm	2,400 (7' 10") Arm	2,920 (9' 7") Arm	3,900 (12' 10") Arm	2,000 (6' 7") Arm	2,400 (7' 10") Arm	2,920 (9' 7") Arm	2,000 (6' 7") Arm	2,400 (7' 10") Arm	2,920 (9' 7") Arm
0.80 (1.05)	0.70 (0.92)	1,070 (42.1)	1,160 (45.7)	770 (1,700)	●	●	●	○	●	●	○	-
0.92 (1.20)	0.80 (1.05)	1,190 (46.9)	1,280 (50.4)	820 (1,810)	●	●	●	○	●	●	○	-
1.10 (1.44)	0.96 (1.26)	1,375 (54.1)	1,465 (57.7)	890 (1,960)	●	●	○	○	●	○	○	-
1.20 (1.57)	1.05 (1.37)	1,390 (54.7)	1,480 (58.3)	920 (2,030)	●	○	○	-	●	○	-	-
1.34 (1.75)	1.17 (1.53)	1,525 (60.0)	1,615 (63.6)	990 (2,180)	○	○	○	-	○	○	-	-
◆ 0.90 (1.18)	0.79 (1.03)	1,210 (47.6)	-	880 (1,940)	●	●	●	○	●	●	○	-
◆ 1.05 (1.37)	0.92 (1.20)	1,355 (53.3)	-	940 (2,070)	●	●	○	○	●	○	○	-
◆ 0.87 (1.14)	0.77 (1.01)	1,195 (47.0)	-	940 (2,070)	●	●	●	○	●	●	○	-
◆ 1.20 (1.57)	1.05 (1.37)	1,520 (59.8)	-	1,120 (2,470)	○	○	-	-	○	○	-	-
★ 0.52 (0.68)	0.45 (0.59)	945 (37.2)	1,020 (40.2)	460 (1,010)	-	-	-	-	-	-	-	○

- ◆ Heavy duty bucket
- ◆ Rock-Heavy duty bucket
- ★ Long reach bucket
- : Applicable for materials with density of 2,000 kg / m<sup>3</sup> (3,370 lb/ yd<sup>3</sup>) or less
- : Applicable for materials with density of 1,600 kg / m<sup>3</sup> (2,700 lb/ yd<sup>3</sup>) or less
- : Applicable for materials with density of 1,100 kg / m<sup>3</sup> (1,850 lb/ yd<sup>3</sup>) or less

### ATTACHMENT

Booms and arms are welded with a low-stress, full-box section design. 5.68 m (18' 8") & 8.2 m (26' 11") Booms and 5.65 m (18' 6") 2-Piece Boom and 2.0 m (6' 7"); 2.4 m (7' 10"); 2.92 m (9' 7"); 3.9 m (12' 10") & 6.3 m (20' 8") Arms are available.

### DIGGING FORCE

Boom	Length	mm (ft.in)	Boom 5,680 (18' 8")				2-Piece Boom 5,650 (18' 6")			8,200 (26' 11")	Remarks:
			1,950 (4,300)				2,600 (5,730)			2,350 (5,180)	
Arm	Length	mm (ft.in)	2,000 (6' 7")	2,400 (7' 10")	2,920 (9' 7")	3,900 (12' 10")	2,000 (6' 7")	2,400 (7' 10")	2,920 (9' 7")	6,300 (20' 8")	
	Weight	kg (lb)	975 (2,150)	1,045 (2,300)	1,095 (2,410)	1,295 (2,850)	975 (2,150)	1,045 (2,300)	1,095 (2,410)	1,330 (2,930)	
Bucket digging force	SAE	kN	133.4 [144.8]	133.4 [144.8]	133.4 [144.8]	133.4 [144.8]	133.4 [144.8]	133.4 [144.8]	133.4 [144.8]	72.6	[ ]: Power Boost
		kgf	13600 [14770]	13600 [14770]	13600 [14770]	13600 [14770]	13600 [14770]	13600 [14770]	13600 [14770]	7400	
		lbf	29980 [32550]	29980 [32550]	29980 [32550]	29980 [32550]	29980 [32550]	29980 [32550]	29980 [32550]	16310	
	ISO	kN	152.0 [165.0]	152.0 [165.0]	152.0 [165.0]	152.0 [165.0]	152.0 [165.0]	152.0 [165.0]	152.0 [165.0]	83.4	
		kgf	15500 [16830]	15500 [16830]	15500 [16830]	15500 [16830]	15500 [16830]	15500 [16830]	15500 [16830]	8500	
		lbf	34170 [37100]	34170 [37100]	34170 [37100]	34170 [37100]	34170 [37100]	34170 [37100]	34170 [37100]	18740	
Arm crowd force	SAE	kN	144.2 [156.5]	119.6 [129.9]	102.0 [110.7]	84.3 [91.6]	144.2 [156.5]	119.6 [129.9]	102.0 [110.7]	49.0	
		kgf	14700 [15960]	12200 [13250]	10400 [11290]	8600 [9340]	14700 [15960]	12200 [13250]	10400 [11290]	5000	
		lbf	32410 [35190]	26900 [29210]	22930 [24900]	18960 [20590]	32410 [35190]	26900 [29210]	22930 [24900]	11020	
	ISO	kN	151.0 [164.0]	125.5 [136.3]	106.9 [116.1]	87.3 [94.8]	151.0 [164.0]	125.5 [136.3]	106.9 [116.1]	50.0	
		kgf	15400 [16720]	12800 [13900]	10900 [11830]	8900 [9660]	15400 [16720]	12800 [13900]	10900 [11830]	5100	
		lbf	33950 [36860]	28220 [30640]	24030 [26090]	19620 [21300]	33950 [36860]	28220 [30640]	24030 [26090]	11240	

Note : Boom weight includes arm cylinder, piping, and pin  
Arm weight includes bucket cylinder, linkage, and pin

# BUCKET SELECTION GUIDE & DIGGING FORCE

## HX220 NL

### BUCKETS

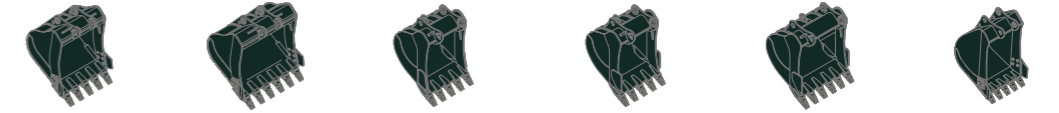

SAE heaped m <sup>3</sup> (yd <sup>3</sup> )	0.80 (1.05) 0.92 (1.20) 1.10 (1.44) 1.20 (1.57)	1.34 (1.75)	◆ 0.90 (1.18) ◆ 1.05 (1.37)	◆ 0.87 (1.14)	◆ 1.20 (1.57)	★ 0.52 (0.68)
---	--	-------------	--------------------------------	---------------	---------------	---------------

Capacity m <sup>3</sup> (yd <sup>3</sup> )	Width mm (in)	Weight kg (lb)	Recommendation mm (ft.in)							
			5,650 (18' 6") Boom			5,650 (18' 6") 2-Piece Boom				
			2,000 (6' 7") Arm	2,400 (7' 10") Arm	2,920 (9' 7") Arm	2,000 (6' 7") Arm	2,400 (7' 10") Arm	2,920 (9' 7") Arm		
0.80 (1.05)	0.70 (0.92)	1,070 (42.1)	1,160 (45.7)	770 (1,700)	●	●	●	●	●	○
0.92 (1.20)	0.80 (1.05)	1,190 (46.9)	1,280 (50.4)	820 (1,810)	●	●	●	●	●	○
1.10 (1.44)	0.96 (1.26)	1,375 (54.1)	1,465 (57.7)	890 (1,960)	●	●	○	●	○	○
1.20 (1.57)	1.05 (1.37)	1,390 (54.7)	1,480 (58.3)	920 (2,030)	●	○	○	●	○	-
1.34 (1.75)	1.17 (1.53)	1,525 (60.0)	1,615 (63.6)	990 (2,180)	○	○	○	○	○	-
◆ 0.90 (1.18)	0.79 (1.03)	1,210 (47.6)	-	880 (1,940)	●	●	●	●	●	○
◆ 1.05 (1.37)	0.92 (1.20)	1,355 (53.3)	-	940 (2,070)	●	●	○	●	○	○
◆ 0.87 (1.14)	0.77 (1.01)	1,195 (47.0)	-	940 (2,070)	●	●	●	●	●	○
◆ 1.20 (1.57)	1.05 (1.37)	1,520 (59.8)	-	1,120 (2,470)	○	○	-	○	○	-
★ 0.52 (0.68)	0.45 (0.59)	945 (37.2)	1,020 (40.2)	460 (1,010)	-	-	-	-	-	-

- ◆ Heavy duty bucket
- ◆ Rock-Heavy duty bucket
- ★ Long reach bucket
- : Applicable for materials with density of 2,000 kg / m<sup>3</sup> (3,370 lb/ yd<sup>3</sup>) or less
- : Applicable for materials with density of 1,600 kg / m<sup>3</sup> (2,700 lb/ yd<sup>3</sup>) or less
- : Applicable for materials with density of 1,100 kg / m<sup>3</sup> (1,850 lb/ yd<sup>3</sup>) or less

### ATTACHMENT

Booms and arms are welded with a low-stress, full-box section design. 5.65 m (18' 6") Boom & 5.65 m (18' 6") 2-Piece Boom and 2.0 m (6' 7"); 2.4 m (7' 10") & 2.92 m (9' 7") Arms are available.

### DIGGING FORCE

Boom	Length	mm (ft.in)	Boom 5,650 (18' 6")				2-Piece Boom 5,650 (18' 6")			Remarks:
			1,950 (4,300)				2,600 (5,730)			
Arm	Length	mm (ft.in)	2,000 (6' 7")	2,400 (7' 10")	2,920 (9' 7")	3,900 (12' 10")	2,000 (6' 7")	2,400 (7' 10")	2,920 (9' 7")	
	Weight	kg (lb)	975 (2,150)	1,045 (2,300)	1,095 (2,410)	1,295 (2,850)	975 (2,150)	1,045 (2,300)	1,095 (2,410)	
Bucket digging force	SAE	kN	133.4 [144.8]	133.4 [144.8]	133.4 [144.8]	133.4 [144.8]	133.4 [144.8]	133.4 [144.8]	133.4 [144.8]	[ ]: Power Boost
		kgf	13600 [14770]	13600 [14770]	13600 [14770]	13600 [14770]	13600 [14770]	13600 [14770]	13600 [14770]	
		lbf	29980 [32550]	29980 [32550]	29980 [32550]	29980 [32550]	29980 [32550]	29980 [32550]	29980 [32550]	
	ISO	kN	152.0 [165.0]	152.0 [165.0]	152.0 [165.0]	152.0 [165.0]	152.0 [165.0]	152.0 [165.0]	152.0 [165.0]	
		kgf	15500 [16830]	15500 [16830]	15500 [16830]	15500 [16830]	15500 [16830]	15500 [16830]	15500 [16830]	
		lbf	34170 [37100]	34170 [37100]	34170 [37100]	34170 [37100]	34170 [37100]	34170 [37100]	34170 [37100]	
Arm crowd force	SAE	kN	144.2 [156.5]	119.6 [129.9]	102.0 [110.7]	84.3 [91.6]	144.2 [156.5]	119.6 [129.9]	102.0 [110.7]	
		kgf	14700 [15960]	12200 [13250]	10400 [11290]	8600 [9340]	14700 [15960]	12200 [13250]	10400 [11290]	
		lbf	32410 [35190]	26900 [29210]	22930 [24900]	18960 [20590]	32410 [35190]	26900 [29210]	22930 [24900]	
	ISO	kN	151.0 [164.0]	125.5 [136.3]	106.9 [116.1]	87.3 [94.8]	151.0 [164.0]	125.5 [136.3]	106.9 [116.1]	
		kgf	15400 [16720]	12800 [13900]	10900 [11830]	8900 [9660]	15400 [16720]	12800 [13900]	10900 [11830]	
		lbf	33950 [36860]	28220 [30640]	24030 [26090]	19620 [21300]	33950 [36860]	28220 [30640]	24030 [26090]	

Note : Boom weight includes arm cylinder, piping, and pin  
Arm weight includes bucket cylinder, linkage, and pin



# DIMENSIONS & WORKING RANGE

## HX220 L DIMENSIONS

5.68 m (18' 8") BOOM and 2.0 m (6' 7"); 2.4 m (7' 10"); 2.92 m (9' 7") & 3.9 m (12' 10") ARM

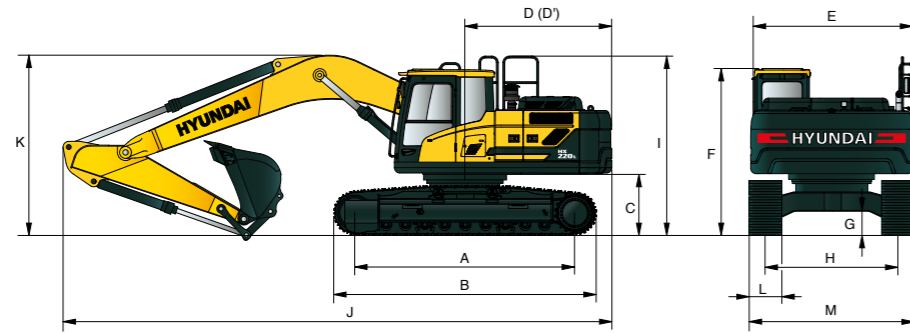

Unit: mm (ft-in)

A	Tumbler distance	3,650 (12' 0")
B	Overall length of crawler	4,404 (14' 4")
C	Ground clearance of counterweight	1,060 (3' 6")
D	Tail swing radius	2,890 (9' 5")
D'	Rear-end length	2,770 (9' 1")
E	Overall width of upperstructure	2,740 (9' 0")
F	Overall height of cab	3,000 (9' 8")
G	Min. ground clearance	480 (1' 7")
H	Track gauge	2,390 (7' 10")
I	Overall height of guardrail	3,210 (10' 5")

Boom length	5,680 (18' 8")				
Arm length	2,000 (6' 7")	2,400 (7' 10")	2,920 (9' 7")	3,900 (12' 10")	
J	Overall length	9,650 (31' 8")	9,570 (31' 5")	9,530 (31' 3")	9,520 (31' 3")
K	Overall height of boom	3,200 (10' 6")	3,110 (10' 2")	3,030 (9' 11")	3,480 (11' 5")
L	Track shoe width	600 (24")	700 (28")	800 (32")	900 (36")
M	Overall width	2,990 (9' 10")	3,090 (10' 2")	3,190 (10' 6")	3,290 (10' 10")

## HX220 L WORKING RANGE

Unit: mm (ft-in)

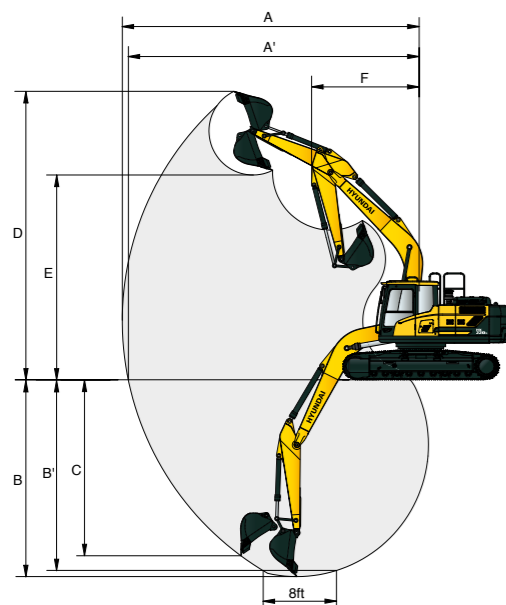

Boom length	5,680 (18' 8")				
Arm length	2,000 (6' 7")	2,400 (7' 10")	2,920 (9' 7")	3,900 (12' 10")	
A	Max. digging reach	9,140 (30' 0")	9,500 (31' 2")	9,980 (32' 9")	10,910 (35' 10")
A'	Max. digging reach on ground	8,960 (29' 5")	9,330 (30' 7")	9,820 (32' 3")	10,770 (35' 4")
B	Max. digging depth	5,820 (19' 1")	6,220 (20' 5")	6,730 (22' 1")	7,720 (25' 4")
B'	Max. digging depth (8' level)	5,580 (18' 4")	6,010 (19' 9")	6,560 (21' 6")	7,580 (24' 10")
C	Max. vertical wall digging depth	5,280 (17' 4")	5,720 (18' 9")	6,280 (20' 7")	7,240 (23' 9")
D	Max. digging height	9,140 (30' 0")	9,340 (30' 8")	9,600 (31' 6")	10,110 (33' 2")
E	Max. dumping height	6,330 (20' 9")	6,520 (21' 5")	6,780 (22' 3")	7,290 (23' 11")
F	Min. front swing radius	3,750 (12' 4")	3,740 (12' 3")	3,670 (12' 0")	3,700 (12' 2")

# DIMENSIONS & WORKING RANGE

## HX220 L 2-PIECE BOOM DIMENSIONS

5.65 m (18' 6") 2-Piece BOOM and 2.0 m (6' 7"); 2.4 m (7' 10") & 2.92 m (9' 7") ARM

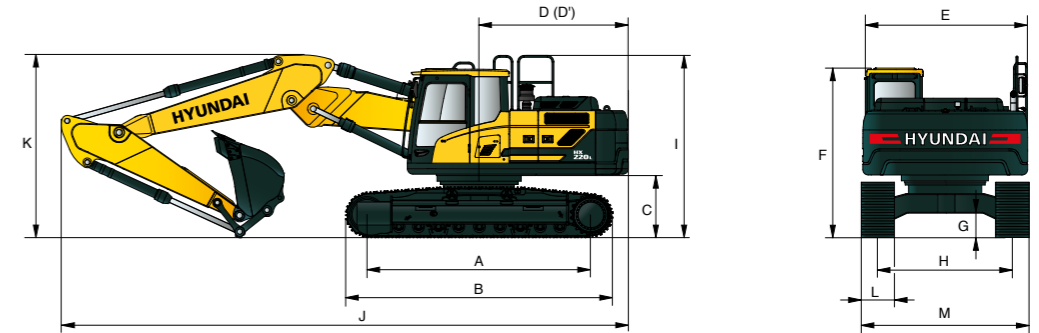

Unit: mm (ft-in)

A	Tumbler distance	3,650 (12' 0")
B	Overall length of crawler	4,404 (14' 4")
C	Ground clearance of counterweight	1,060 (3' 6")
D	Tail swing radius	2,890 (9' 5")
D'	Rear-end length	2,770 (9' 1")
E	Overall width of upperstructure	2,740 (9' 0")
F	Overall height of cab	3,000 (9' 8")
G	Min. ground clearance	480 (1' 7")
H	Track gauge	2,390 (7' 10")
I	Overall height of guardrail	3,210 (10' 5")

Boom length	5,650 (18' 6") 2-Piece Boom				
Arm length	2,000 (6' 7")	2,400 (7' 10")	2,920 (9' 7")		
J	Overall length	9,650 (31' 8")	9,570 (31' 5")	9,530 (31' 3")	
K	Overall height of boom	3,200 (10' 6")	3,110 (10' 2")	3,030 (9' 11")	
L	Track shoe width	600 (24")	700 (28")	800 (32")	900 (36")
M	Overall width	2,990 (9' 10")	3,090 (10' 2")	3,190 (10' 6")	3,290 (10' 10")

## HX220 L 2-PIECE BOOM WORKING RANGE

Unit: mm (ft-in)

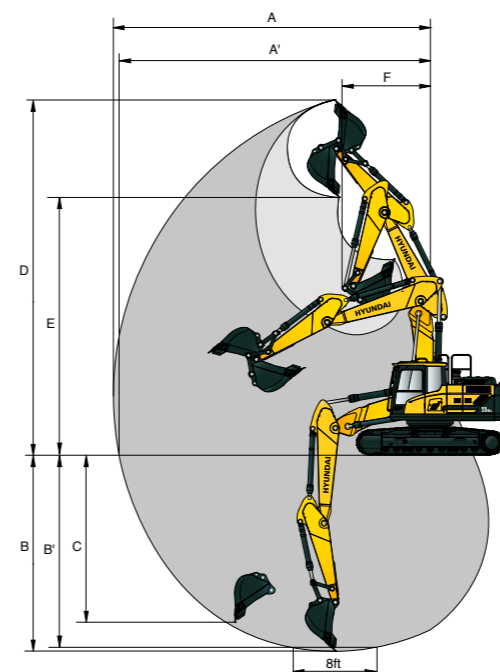

Boom length	5,650 (18' 6") 2-Piece Boom			
Arm length	2,000 (6' 7")	2,400 (7' 10")	2,920 (9' 7")	
A	Max. digging reach	9,120 (29' 11")	9,530 (31' 3")	10,020 (32' 10")
A'	Max. digging reach on ground	8,950 (29' 4")	9,360 (30' 8")	9,860 (32' 4")
B	Max. digging depth	5,820 (19' 1")	5,880 (19' 3")	6,400 (21' 0")
B'	Max. digging depth (8' level)	5,480 (18' 0")	5,770 (18' 11")	6,290 (20' 8")
C	Max. vertical wall digging depth	5,360 (17' 7")	5,020 (16' 6")	5,560 (18' 3")
D	Max. digging height	10,310 (33' 10")	10,670 (35' 0")	11,090 (36' 5")
E	Max. dumping height	7,390 (24' 3")	7,750 (25' 5")	8,160 (26' 9")
F	Min. front swing radius	2,870 (9' 5")	2,660 (8' 9")	2,530 (8' 4")



# DIMENSIONS & WORKING RANGE

## HX220 L LONG REACH DIMENSIONS

8.2 m (26' 11") BOOM and 6.3 m (20' 8") ARM

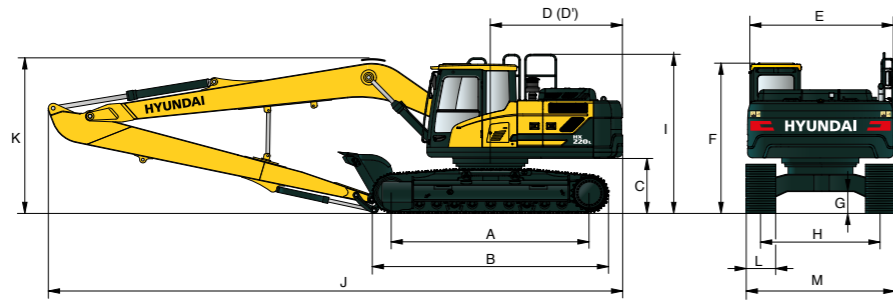

Unit: mm (ft-in)

A	Tumbler distance	3,650 (12' 0")	Boom length	8,200 (26' 11")	
B	Overall length of crawler	4,404 (14' 4")	Arm length	6,300 (20' 8")	
C	Ground clearance of counterweight	1,060 (3' 6")	J	Overall length	12,030 (39' 6")
D	Tail swing radius	2,890 (9' 5")	K	Overall height of boom	3,280 (10' 9")
D'	Rear-end length	2,770 (9' 1")	L	Track shoe width	800 (32")
E	Overall width of upperstructure	2,740 (9' 0")	M	Overall width	3,190 (10' 6")
F	Overall height of cab	3,000 (9' 8")			
G	Min. ground clearance	480 (1' 7")			
H	Track gauge	2,390 (7' 10")			
I	Overall height of guardrail	3,210 (10' 5")			

## HX220 L LONG REACH WORKING RANGE

Unit: mm (ft-in)

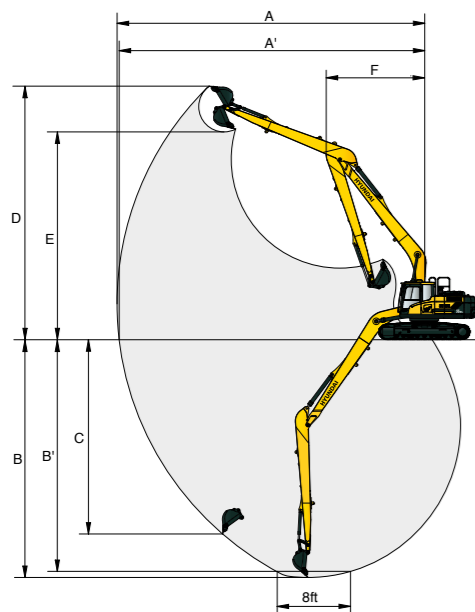

	Boom length	8,200 (26' 11")
	Arm length	6,300 (20' 8")
A	Max. digging reach	15,220 (50' 0")
A'	Max. digging reach on ground	15,120 (49' 7")
B	Max. digging depth	11,760 (38' 7")
B'	Max. digging depth (8' level)	11,650 (38' 3")
C	Max. vertical wall digging depth	9,610 (31' 6")
D	Max. digging height	12,550 (41' 2")
E	Max. dumping height	10,280 (33' 8")
F	Min. front swing radius	4,870 (16' 0")

# DIMENSIONS & WORKING RANGE

## HX220 L HIGH WALKER DIMENSIONS

5.68 m (18' 8") BOOM and 2.0 m (6' 7"); 2.4 m (7' 10") & 2.92 m (9' 7") ARM

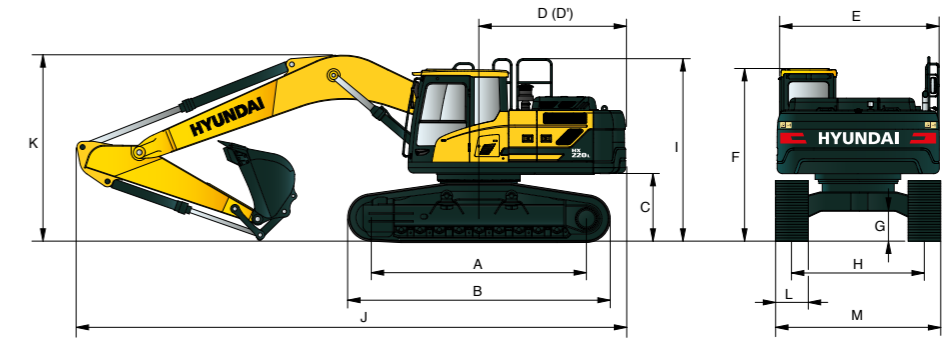

Unit: mm (ft-in)

A	Tumbler distance	3,650 (12' 0")	Boom length	5,680 (18' 8")				
B	Overall length of crawler	4,404 (14' 4")	Arm length	2,000 (6' 7")	2,400 (7' 10")	2,920 (9' 7")	3,900 (12' 10")	
C	Ground clearance of counterweight	1,260 (4' 1")	D	Tail swing radius	2,890 (9' 5")			
D	Tail swing radius	2,890 (9' 5")	D'	Rear-end length	2,770 (9' 1")			
D'	Rear-end length	2,770 (9' 1")	E	Overall width of upperstructure	2,740 (9' 0")			
E	Overall width of upperstructure	2,740 (9' 0")	F	Overall height of cab	3,200 (10' 5")			
F	Overall height of cab	3,200 (10' 5")	G	Min. ground clearance	660 (2' 2")			
G	Min. ground clearance	660 (2' 2")	H	Track gauge	2,795 (9' 2")			
H	Track gauge	2,795 (9' 2")	I	Overall height of guardrail	3,410 (11' 2")			
I	Overall height of guardrail	3,410 (11' 2")						
L	Track shoe	type	Triple grouser				Double grouser	
		width	600 (24")	700 (28")	800 (32")	900 (36")	600 (24")	700 (28")
M	Overall width	3,395 (11' 2")		3,495 (11' 6")	3,595 (11' 10")	3,695 (12' 2")	3,395 (11' 2")	3,495 (11' 6")

## HX220 L HIGH WALKER WORKING RANGE

Unit: mm (ft-in)

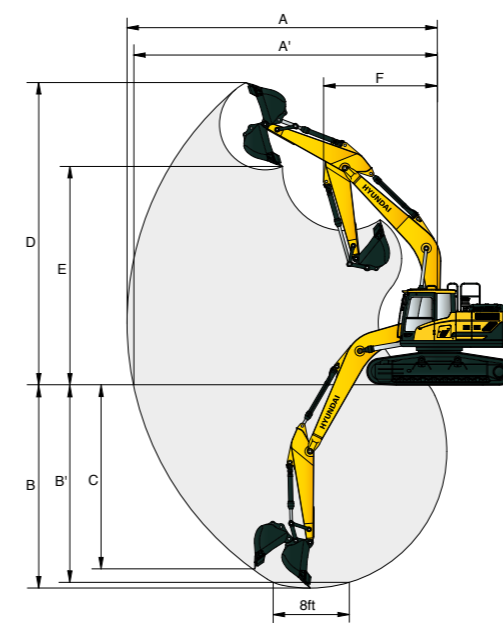

	Boom length	5,680 (18' 8")			
	Arm length	2,000 (6' 7")	2,400 (7' 10")	2,920 (9' 7")	3,900 (12' 10")
A	Max. digging reach	9,140 (30' 0")	9,500 (31' 2")	9,980 (32' 9")	10,910 (35' 10")
A'	Max. digging reach on ground	8,920 (29' 3")	9,290 (30' 6")	9,820 (32' 3")	10,730 (35' 2")
B	Max. digging depth	5,630 (18' 6")	6,010 (19' 9")	6,550 (21' 6")	7,530 (24' 8")
B'	Max. digging depth (8' level)	5,390 (17' 8")	5,820 (19' 1")	6,380 (20' 11")	7,390 (24' 3")
C	Max. vertical wall digging depth	5,090 (16' 8")	5,630 (18' 6")	6,100 (20' 0")	7,050 (23' 1")
D	Max. digging height	9,330 (30' 7")	9,530 (31' 3")	9,780 (32' 1")	10,300 (33' 9")
E	Max. dumping height	6,520 (21' 5")	6,710 (22' 0")	6,960 (22' 10")	7,480 (24' 6")
F	Min. front swing radius	3,750 (12' 4")	3,740 (12' 3")	3,670 (12' 0")	3,700 (12' 2")



# DIMENSIONS & WORKING RANGE

## HX220 NL DIMENSIONS

5.65 m (18' 6") BOOM and 2.0 m (6' 7"); 2.4 m (7' 10") & 2.92 m (9' 7") ARM

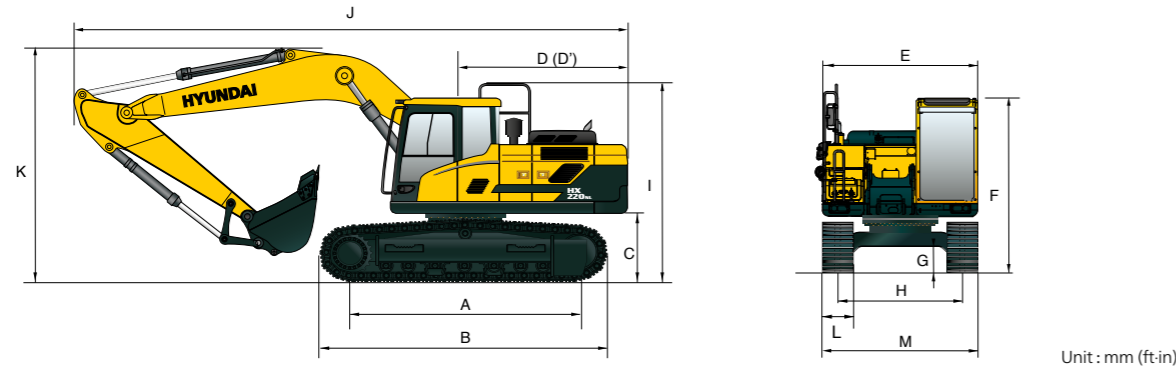

Unit: mm (ft-in)	
A Tumbler distance	3,650 (12' 0")
B Overall length of crawler	4,404 (14' 4")
C Ground clearance of counterweight	1,060 (3' 6")
D Tail swing radius	2,850 (9' 4")
D' Rear-end length	2,770 (9' 1")
E Overall width of upperstructure	2,530 (8' 4")
F Overall height of cab	3,000 (9' 8")
G Min. ground clearance	480 (1' 7")
H Track gauge	2,000 (6' 7")
I Overall height of guardrail	3,210 (10' 5")
Boom length	5,650 (18' 6")
Arm length	2,000 (6' 7")    2,400 (7' 10")    2,920 (9' 7")
J Overall length	9,650 (31' 8")    9,570 (31' 5")    9,510 (31' 23")
K Overall height of boom	3,250 (10' 8")    3,170 (10' 5")    3,100 (10' 2")
L Track shoe width	500 (20")    600 (24")    700 (28")
M Overall width	2,500 (8' 2")    2,600 (8' 6")    2,700 (8' 10")

## HX220 NL WORKING RANGE

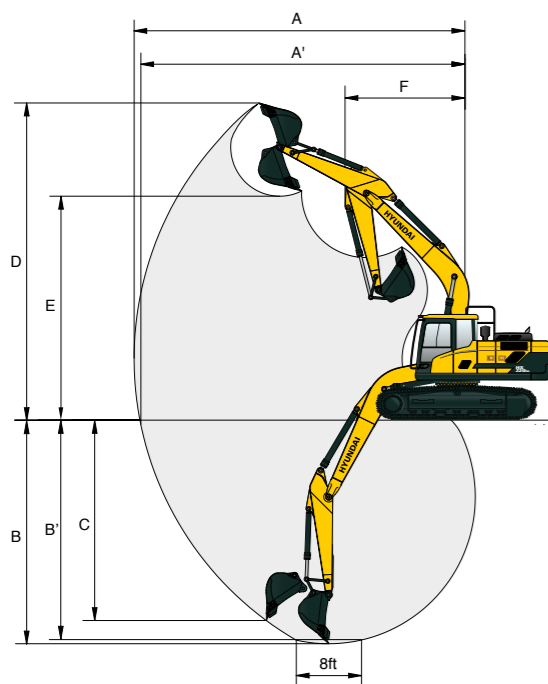

Unit: mm (ft-in)	
Boom length	5,650 (18' 6")
Arm length	2,000 (6' 7")    2,400 (7' 10")    2,920 (9' 7")
A Max. digging reach	9,140 (30' 0")    9,500 (31' 2")    9,960 (32' 8")
A' Max. digging reach on ground	8,960 (29' 5")    9,340 (30' 8")    9,800 (32' 2")
B Max. digging depth	5,750 (18' 10")    6,150 (20' 2")    6,640 (21' 9")
B' Max. digging depth (8' level)	5,520 (18' 1")    5,950 (19' 6")    6,470 (21' 36")
C Max. vertical wall digging depth	5,320 (17' 5")    5,780 (19' 9")    6,250 (20' 6")
D Max. digging height	9,270 (30' 5")    9,500 (31' 2")    9,740 (31' 11")
E Max. dumping height	6,450 (21' 2")    6,660 (21' 10")    6,900 (22' 8")
F Min. front swing radius	3,710 (12' 2")    3,630 (11' 11")    3,580 (11' 9")

# DIMENSIONS & WORKING RANGE

## HX220 NL 2-PIECE BOOM DIMENSIONS

5.65 m (18' 6") 2-Piece BOOM and 2.0 m (6' 7"); 2.4 m (7' 10") & 2.92 m (9' 7") ARM

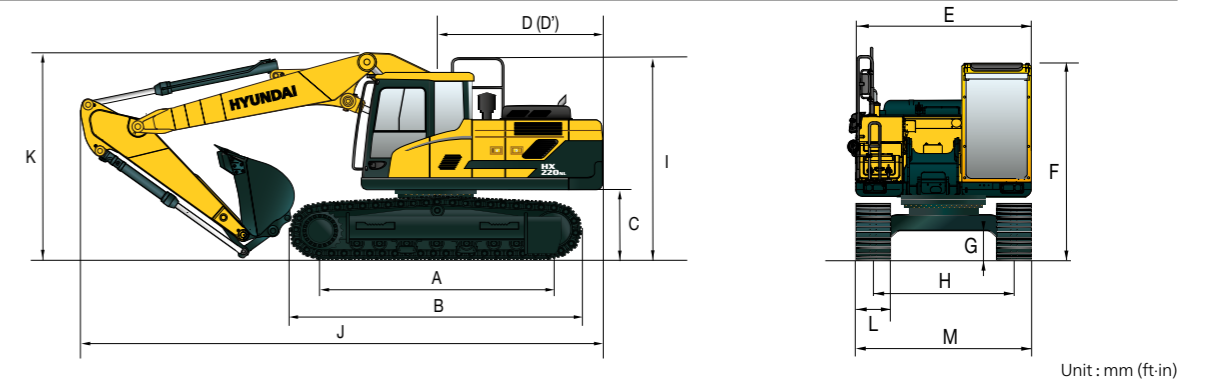

Unit: mm (ft-in)	
A Tumbler distance	3,650 (12' 0")
B Overall length of crawler	4,404 (14' 4")
C Ground clearance of counterweight	1,060 (3' 6")
D Tail swing radius	2,850 (9' 4")
D' Rear-end length	2,770 (9' 1")
E Overall width of upperstructure	2,530 (8' 4")
F Overall height of cab	3,000 (9' 8")
G Min. ground clearance	480 (1' 7")
H Track gauge	2,000 (6' 7")
I Overall height of guardrail	3,210 (10' 5")
Boom length	5,650 (18' 6") 2-Piece Boom
Arm length	2,000 (6' 7")    2,400 (7' 10")    2,920 (9' 7")
J Overall length	9,650 (31' 8")    9,570 (31' 5")    9,520 (31' 2")
K Overall height of boom	3,200 (10' 6")    3,000 (9' 10")    3,030 (9' 11")
L Track shoe width	500 (20")    600 (24")    700 (28")
M Overall width	2,500 (8' 2")    2,600 (8' 6")    2,700 (8' 10")

## HX220 NL 2-PIECE BOOM WORKING RANGE

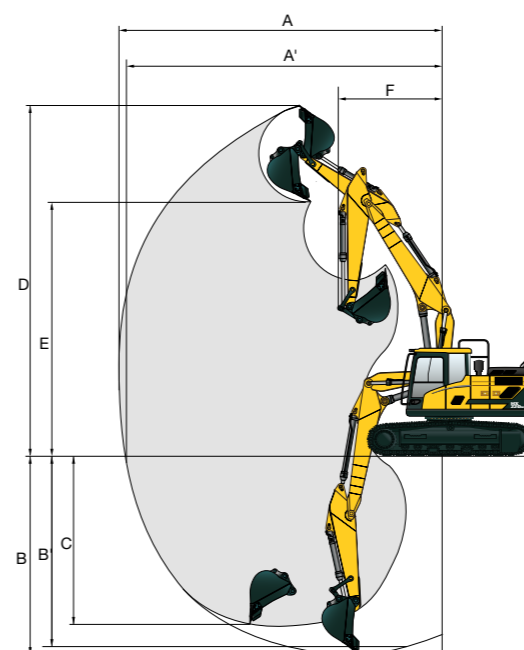

Unit: mm (ft-in)	
Boom length	5,650 (18' 6") 2-Piece Boom
Arm length	2,000 (6' 7")    2,400 (7' 10")    2,920 (9' 7")
A Max. digging reach	9,120 (29' 11")    9,530 (31' 3")    10,020 (32' 10")
A' Max. digging reach on ground	8,940 (29' 4")    9,360 (30' 9")    9,860 (32' 4")
B Max. digging depth	5,480 (18' 0")    5,890 (19' 4")    6,400 (21' 0")
B' Max. digging depth (8' level)	5,360 (17' 7")    5,770 (18' 11")    6,300 (20' 8")
C Max. vertical wall digging depth	4,560 (15' 0")    4,990 (16' 4")    5,530 (18' 2")
D Max. digging height	10,300 (33' 10")    10,670 (35' 0")    11,080 (36' 4")
E Max. dumping height	7,390 (24' 3")    7,740 (25' 5")    8,160 (26' 9")
F Min. front swing radius	2,870 (9' 5")    2,670 (8' 9")    2,530 (8' 4")



# LIFTING CAPACITY

Rating over-front Rating over-side or 360 degrees

## HX220 L

5.68 m (18' 8") Boom; 2.00 m (6' 7") arm equipped with 0.92 m<sup>3</sup> (SAE heaped) bucket and 600 mm (24") triple grouser shoes.

Load point height m (ft)	Load radius								At max. reach		
	3.0 m (10 ft)		4.5 m (15 ft)		6.0 m (20 ft)		7.5 m (25 ft)		Capacity	Reach	
7.5 m (25 ft)	kg								*3970	*3970	6.65
	lb								*8750	*8750	(21.8)
6.0 m (20 ft)	kg			*4400	*4400				*4020	3030	7.78
	lb			*9700	*9700				*8860	6680	(25.5)
4.5 m (15 ft)	kg		*5690	*5690	*4820	4640			*4140	2530	8.43
	lb		*12540	*12540	*10630	10230			*9130	5580	(27.7)
3.0 m (10 ft)	kg		*7420	6860	*5570	4370	*4780	3000	4050	2300	8.74
	lb		*16360	15120	*12280	9630	*10540	6610	8930	5070	(28.7)
1.5 m (5 ft)	kg		*8940	6340	*6340	4120	5080	2880	3990	2250	8.73
	lb		*19710	13980	*13980	9080	11200	6350	8800	4960	(28.6)
Ground Line	kg		*9640	6110	*6860	3960	4990	2810	4210	2370	8.42
	lb		*21250	13470	*15120	8730	11000	6190	9280	5220	(27.6)
-1.5 m (-5 ft)	kg	*13940	12320	*9580	6090	*6950	3910		4830	2750	7.76
	lb	*30730	27160	*21120	13430	*15320	8620		10650	6060	(25.5)
-3.0 m (-10 ft)	kg	*12450	*12450	*8770	6200	*6310	4000		*4800	3650	6.61
	lb	*27450	*27450	*19330	13670	*13910	8820		*10580	8050	(21.7)
-4.5 m (-15 ft)	kg	*9410	*9410								
	lb	*20750	*20750								

5.68 m (18' 8") Boom; 2.40 m (7' 10") arm equipped with 0.92 m<sup>3</sup> (SAE heaped) bucket and 600 mm (24") triple grouser shoes.

Load point height m (ft)	Load radius								At max. reach				
	1.5 m (5 ft)		3.0 m (10 ft)		4.5 m (15 ft)		6.0 m (20 ft)		7.5 m (25 ft)		Capacity	Reach	
7.5 m (25 ft)	kg										*3660	3640	7.15
	lb										*8070	8020	(23.5)
6.0 m (20 ft)	kg					*3970	*3970				*3730	2750	8.20
	lb					*8750	*8750				*8220	6060	(26.9)
4.5 m (15 ft)	kg					*4450	*4450	*4190	3120		*3860	2320	8.82
	lb					*9810	*9810	*9240	6880		*8510	5110	(28.9)
3.0 m (10 ft)	kg			*6850	*6850	*5240	4410	*4520	3010		3760	2120	9.11
	lb			*15100	*15100	*11550	9720	*9960	6640		8290	4670	(29.9)
1.5 m (5 ft)	kg			*8510	6400	*6080	4130	*4930	2880		3710	2070	9.10
	lb			*18760	14110	*13400	9110	*10870	6350		8180	4560	(29.9)
Ground Line	kg		*8830	*8830	*9440	6100	*6700	3940	4960	2770	3890	2170	8.18
	lb		*19470	*19470	*20810	13450	*14770	8690	10930	6110	8580	4780	(26.8)
-1.5 m (-5 ft)	kg	*9800	*9800	*13550	12120	*9610	6020	*6920	3860		4400	2480	7.12
	lb	*21610	*21610	*29870	26720	*21190	13270	*15260	8510		9700	5470	(23.4)
-3.0 m (-10 ft)	kg	*14180	*14180	*13180	12340	*9040	6100	*6540	3900		*4660	3190	
	lb	*31260	*31260	*29060	27210	*19930	13450	*14420	8600		*10270	7030	
-4.5 m (-15 ft)	kg			*10580	*10580	*7350	6350						
	lb			*23320	*23320	*16200	14000						

1. Lifting capacity are based on SAE J1097 and ISO 10567.

2. Lifting capacity of the HX series does not exceed 75% of tipping load with the machine on firm, level ground or 87% of full hydraulic capacity.

3. The load point is a hook located on the back of the bucket.

4. (\*) indicates load limited by hydraulic capacity.

# LIFTING CAPACITY

Rating over-front Rating over-side or 360 degrees

## HX220 L

5.68 m (18' 8") Boom; 2.92 m (9' 7") arm equipped with 0.92 m<sup>3</sup> (SAE heaped) bucket and 600 mm (24") triple grouser shoes.

Load point height m (ft)	Load radius								At max. reach						
	1.5 m (5 ft)		3.0 m (10 ft)		4.5 m (15 ft)		6.0 m (20 ft)		7.5 m (25 ft)		Capacity	Reach			
7.5 m (25 ft)	kg										*3310	3140	7.78		
	lb										*7300	6920	(25.5)		
6.0 m (20 ft)	kg										*2300	*2300	*3400	2450	8.74
	lb										*5070	*5070	*7500	5400	(28.7)
4.5 m (15 ft)	kg							*3970	*3970		*3780	3170	*3530	2090	9.32
	lb							*8750	*8750		6990	6990	*7780	4610	(30.6)
3.0 m (10 ft)	kg			*9720	*9720	*6100	*6100	*4790	4460		*4180	3030	3440	1910	9.59
	lb			*21430	*21430	*13450	*13450	*10560	9830		*9220	6680	7580	4210	(31.5)
1.5 m (5 ft)	kg			*8850	*8850	*7900	6500	*5700	4150		*4660	2870	3380	1860	9.59
	lb			*19510	*19510	*17420	14330	*12570	9150		*10270	6330	7450	4100	(31.5)
Ground Line	kg			*9590	*9590	*9100	6100	*6440	3920		4930	2740	3520	1930	9.31
	lb			*21140	*21140	*20060	13450	*14200	8640		10870	6040	7760	4250	(30.5)
-1.5 m (-5 ft)	kg	*8840	*8840	*12650	11920	*9540	5940	*6810	3800		4860	2680	3910	2170	8.72
	lb	*19490	*19490	*27980	26280	*21030	13100	*15010	8380		10710	5910	8620	4780	(28.6)
-3.0 m (-10 ft)	kg	*12230	*12230	*13910	12080	*9260	5960	*6690	3800				*4420	2700	7.75
	lb	*26960	*26960	*30670	26630	*20410	13140	*14750	8380				*9740	5950	(25.4)
-4.5 m (-15 ft)	kg			*11800	*11800	*8060	6150						*4280	4080	6.16
	lb			*26010	*26010	*17770	13560						*9440	8990	(20.2)

5.68 m (18' 8") Boom; 3.90 m (12' 9") arm equipped with 0.92 m<sup>3</sup> (SAE heaped) bucket and 600 mm (24") triple grouser shoes.

Load point height m (ft)	Load radius								At max. reach											
	1.5 m (5 ft)		3.0 m (10 ft)		4.5 m (15 ft)		6.0 m (20 ft)		7.5 m (25 ft)		9.0 m (30 ft)		Capacity	Reach						
9.0 m (30 ft)	kg												*2700	*2700	7.66					
	lb												*5950	*5950	(25.1)					
7.5 m (25 ft)	kg									*1940	*1940		*2760	*2760	8.94					
	lb									*4280	*4280		*6080	*6080	(29.3)					
6.0 m (20 ft)	kg									*2790	*2790		*2850	2600	9.77					
	lb									*6150	*6150		*6280	5730	(32.1)					
4.5 m (15 ft)	kg									*3050	*3050	*2000	*2000	*2970	2300	10.28				
	lb									*6720	*6720	*4410	*4410	*6550	5070	(33.7)				
3.0 m (10 ft)	kg							*3900	*3900	*3510	*3510	*2870	2860	*3110	2140	10.52				
	lb							*8600	*8600	*7740	*7740	*6330	6310	*6860	4720	(34.5)				
1.5 m (5 ft)	kg							*11080	*11080	*6600	*6600	*4900	*4900	*4080	3820	*3410	2760	3080	2090	10.52
	lb							*24430	*24430	*14550	*14550	*10800	*10800	*8990	8420	*7520	6080	6790	4610	(34.5)
Ground Line	kg	*5300	*5300	*10640	*10640	*8200	*8200	*5820	5210		*4610	3630	*3490	2660	3180	2150	10.27			
	lb	*11680	*11680	*23460	*23460	*18080	*18080	*12830	11490		*10160	8000	*7690	5860	7010	4740	(33.7)			
-1.5 m (-5 ft)	kg	*7540	*7540	*11690	*11690	*9110	7900	*6440	4990		*4990	3510	*2330	*2330	3450	2340	9.75			
	lb	*16620	*16620	*25770	*25770	*20080	17420	*14200	11000		*11000	7740	*5140	*5140	7610	5160	(32.0)			
-3.0 m (-10 ft)	kg	*10030	*10030	*14390	*14390	*9320	7800	*6660	4910		*5070	3470			*3850	2750	8.91			
	lb	*22110	*22110	*31720	*31720	*20550	17200	*14680	10820		*11180	7650			*8490	6060	(29.2)			
-4.5 m (-15 ft)	kg	*13000	*13000	*13310	*13310	*8780	7890	*6290	4960						*3990	3640	7.62			
	lb	*28660	*28660	*29340	*29340	*19360	17390	*13870	10930						*8800	8020	(25.0)			
-6.0 m (-20 ft)	kg			*10560	*10560	*7050</														













# LIFTING CAPACITY











 Rating over-front  Rating over-side or 360 degrees

## HX220 L 2-PIECE BOOM

5.65 m (18' 6") 2-Piece Boom; 2.00 m (6' 7") arm equipped with 0.92 m<sup>3</sup> (SAE heaped) bucket and 600 mm (24") triple grouser shoes.

Load point height m (ft)	Load radius								At max. reach		
	3.0 m (10 ft)		4.5 m (15 ft)		6.0 m (20 ft)		7.5 m (25 ft)		Capacity	Reach	
											m (ft)
10.5 m (35 ft)	kg								*6180	*6180	4.64
	lb								*13620	*13620	(15.2)
9.0 m (30 ft)	kg								*6520	*6520	4.61
	lb								*14370	*14370	(15.1)
7.5 m (25 ft)	kg		*6710	*6710					*5270	4060	6.67
	lb		*14790	*14790					*11620	8950	(21.9)
6.0 m (20 ft)	kg		6780	*6870	*5850	4780			*4850	2970	7.80
	lb		15150	*15150	*12900	10540			*10690	6550	(25.6)
4.5 m (15 ft)	kg	*11340	*11340	*7750	7500	*6130	4610		4360	2470	8.45
	lb	*25000	*25000	*17090	16530	*13510	10160		9610	5450	(27.7)
3.0 m (10 ft)	kg		*8930	6810	*6590	4330	5200	2950	4030	2250	8.75
	lb		*19690	15010	*14530	9550	11460	6500	8880	4960	(28.7)
1.5 m (5 ft)	kg		*9600	6250	*6900	4060	5070	2830	3980	2200	8.75
	lb		*21160	13780	*15210	8950	11180	6240	8770	4850	(28.7)
Ground Line	kg		*9290	6020	*6800	3890	4990	2760	*3940	2330	8.44
	lb		*20480	13270	*14990	8580	11000	6080	*8690	5140	(27.7)
-1.5 m (-5 ft)	kg	*9840	*9840	*8130	6010	*6060	3850		*3360	2710	7.77
	lb	*21690	*21690	*17920	13250	*13360	8490		*7410	5970	(25.5)
-3.0 m (-10 ft)	kg			*6030	*6030	*4250	3970				
	lb			*13290	*13290	*9370	8750				

5.65 m (18' 6") 2-Piece Boom; 2.40 m (7' 10") arm equipped with 0.92 m<sup>3</sup> (SAE heaped) bucket and 600 mm (24") triple grouser shoes.

Load point height m (ft)	Load radius								At max. reach		
	3.0 m (10 ft)		4.5 m (15 ft)		6.0 m (20 ft)		7.5 m (25 ft)		Capacity	Reach	
											m (ft)
9.0 m (30 ft)	kg								*5690	*5690	5.40
	lb								*12540	*12540	(17.7)
7.5 m (25 ft)	kg			*5860	*5860				*4850	3560	7.19
	lb			*12920	*12920				*10690	7850	(23.6)
6.0 m (20 ft)	kg			*6410	*6410	*5520	4860		*4510	2690	8.23
	lb			*14130	*14130	*12170	10710		*9940	5930	(27.0)
4.5 m (15 ft)	kg	*10290	*10290	*7300	*7300	*5860	4670	*4360	4020	2260	8.85
	lb	*22690	*22690	*16090	*16090	*12920	10300	*9610	8860	4980	(29.0)
3.0 m (10 ft)	kg			*8550	6940	*6370	4370	*5170	3740	2060	9.14
	lb			*18850	15300	*14040	9630	*11140	8250	4540	(30.0)
1.5 m (5 ft)	kg			*9440	6320	*6780	4070	5070	3690	2020	9.13
	lb			*20810	13930	*14950	8970	11180	8140	4450	(30.0)
Ground Line	kg	*8600	*8600	*9420	6000	*6820	3870	4960	*3760	2120	8.84
	lb	*18960	*18960	*20770	13230	*15040	8530	10930	*8290	4670	(29.0)
-1.5 m (-5 ft)	kg	*11240	*11240	*8510	5930	*6280	3800	*4460	*3310	2440	8.21
	lb	*24780	*24780	*18760	13070	*13850	8380	*9830	*7300	5380	(26.9)
-3.0 m (-10 ft)	kg			*6700	6040	*4870	3860				
	lb			*14770	13320	*10740	8510				

1. Lifting capacity are based on SAE J1097 and ISO 10567.
2. Lifting capacity of the HX series does not exceed 75% of tipping load with the machine on firm, level ground or 87% of full hydraulic capacity.











3. The load point is a hook located on the back of the bucket.
4. (\*) indicates load limited by hydraulic capacity.

# LIFTING CAPACITY

 Rating over-front  Rating over-side or 360 degrees

## HX220 L 2-PIECE BOOM

5.65 m (18' 6") 2-Piece Boom; 2.92 m (9' 7") arm equipped with 0.92 m<sup>3</sup> (SAE heaped) bucket and 600 mm (24") triple grouser shoes.

Load point height m (ft)	Load radius								At max. reach		
	3.0 m (10 ft)		4.5 m (15 ft)		6.0 m (20 ft)		7.5 m (25 ft)		Capacity	Reach	
											m (ft)
9.0 m (30 ft)	kg			*3290	*3290				*4590	*4590	6.28
	lb			*7250	*7250				*10120	*10120	(20.6)
7.5 m (25 ft)	kg					*3520	*3520		*4020	3060	7.83
	lb					*7760	*7760		*8860	6750	(25.7)
6.0 m (20 ft)	kg			*5160	*5160	*4870	*4870	*2440	*3790	2370	8.79
	lb			*11380	*11380	*10740	*10740	*5380	*8360	5220	(28.8)
4.5 m (15 ft)	kg			*6680	*6680	*5480	4750	*4380	3650	2020	9.36
	lb			*14730	*14730	*12080	10470	*9660	8050	4450	(30.7)
3.0 m (10 ft)	kg	*12620	*12620	*8000	7130	*6060	4430	*4970	3400	1850	9.63
	lb	*27820	*27820	*17640	15720	*13360	9770	*10960	7500	4080	(31.6)
1.5 m (5 ft)	kg	*8680	*8680	*9130	6430	*6580	4100	5070	3350	1800	9.63
	lb	*19140	*19140	*20130	14180	*14510	9040	11180	7390	3970	(31.6)
Ground Line	kg	*9390	*9390	*9450	6000	*6780	3850	4930	3500	1880	9.35
	lb	*20700	*20700	*20830	13230	*14950	8490	10870	7720	4140	(30.7)
-1.5 m (-5 ft)	kg	*12500	11770	*8880	5850	*6460	3730	*4770	*3200	2130	8.77
	lb	*27560	25950	*19580	12900	*14240	8220	*10520	*7050	4700	(28.8)
-3.0 m (-10 ft)	kg	*9950	*9950	*7420	5890	*5420	3750				
	lb	*21940	*21940	*16360	12990	*11950	8270				

1. Lifting capacity are based on SAE J1097 and ISO 10567.
2. Lifting capacity of the HX series does not exceed 75% of tipping load with the machine on firm, level ground or 87% of full hydraulic capacity.

3. The load point is a hook located on the back of the bucket.
4. (\*) indicates load limited by hydraulic capacity.



# LIFTING CAPACITY

Rating over-front Rating over-side or 360 degrees

## HX220 L LONG REACH

8.2 m (26' 11") Boom; 6.3 m (20' 8") arm equipped with 0.52 m<sup>3</sup> (SAE heaped) bucket and 800 mm (32") triple grouser shoes.

Load point height m (ft)		Load radius								At max. reach								
		4.5 m (15 ft)		6.0 m (20 ft)		7.5 m (25 ft)		9.0 m (30 ft)		10.5 m (35 ft)		12.0 m (40 ft)		13.5 m (45 ft)		Capacity	Reach	
																	m (ft)	
10.5 m (35 ft)	kg lb														*1470 *3240	*1470 *3240	12.11 (39.7)	
9.0 m (30 ft)	kg lb														*1490 *2050	*1490 *2050	13.11 (43.0)	
7.5 m (25 ft)	kg lb														*1530 *3400	*1350 *3400	13.84 (45.4)	
6.0 m (20 ft)	kg lb														*1580 *3510	*1190 *3510	14.37 (47.1)	
4.5 m (15 ft)	kg lb														*1770 *3900	*1770 *3900	14.72 (48.3)	
3.0 m (10 ft)	kg lb														*2000 *5510	*2000 *5510	14.89 (48.9)	
1.5 m (5 ft)	kg lb	*5570 *12280	*5570 *12280	*3900 *8600	*3900 *8600	*3060 *6750	*3060 *6750	*2560 *5640	*2560 *5640	*2240 *4940	2050 4520	*2030 *4480	1570 3460	*1790 *3950	1200 2650	*1780 *3920	970 2140	14.90 (48.9)
Ground Line	kg lb	*6930 *15280	6870 15150	*4720 *10410	4590 10120	*3580 *7890	3320 7320	*2910 *6420	2490 5490	*2490 *5490	1910 4210	*2200 *4850	1480 3260	*1820 *4010	1140 2510	*1860 *4100	960 2120	14.75 (48.4)
-1.5 m (-5 ft)	kg lb	*7750 *17090	6340 13980	*5330 *11750	4220 9300	*4020 *8860	3060 6750	*3220 *7100	2320 5110	*2700 *5950	1790 3950	*2350 *5180	1400 3090	*1570 *3460	1100 2430	*1960 *4320	990 2180	14.42 (47.3)
-3.0 m (-10 ft)	kg lb	*8150 *17970	6120 13490	*5720 *12610	4000 8820	*4330 *9550	2890 6370	*3450 *7610	2190 4830	*2870 *6330	1700 3750	*2460 *5420	1340 2950			*2060 *4540	1050 2310	13.92 (45.7)
-4.5 m (-15 ft)	kg lb	*8220 *18120	6060 13360	*5890 *12990	3910 8620	*4490 *9900	2810 6190	*3590 *7910	2120 4670	*2960 *6530	1660 3660	*2490 *5490	1330 2930			*2180 *4810	1170 2580	13.20 (43.3)
-6.0 m (-20 ft)	kg lb	*8020 *17680	6130 13510	*5840 *12870	3920 8640	*4500 *9920	2790 6150	*3600 *7940	2110 4650	*2940 *6480	1660 3660					*2310 *5090	1370 3020	12.25 (40.2)
-7.5 m (-25 ft)	kg lb	*7500 *16530	6310 13910	*5550 *12240	4010 8840	*4300 *9480	2850 6280	*3420 *7540	2170 4780	*2700 *5950	1730 3810					*2430 *5360	1710 3770	10.97 (36.0)
-9.0 m (-30 ft)	kg lb	*6570 *14480	*6570 *14480	*4920 *10850	4200 9260	*3790 *8360	3000 6610	*2890 *6370	2320 5110									
-10.5 m (-35 ft)	kg lb	*4970 *10960	*4970 *10960	*3680 *8110	*3680 *8110													

- Lifting capacity are based on SAE J1097 and ISO 10567.
- Lifting capacity of the HX series does not exceed 75% of tipping load with the machine on firm, level ground or 87% of full hydraulic capacity.
- The load point is a hook located on the back of the bucket.
- (\*) indicates load limited by hydraulic capacity.

# LIFTING CAPACITY

Rating over-front Rating over-side or 360 degrees

## HX220 L HIGH WALKER

5.68 m (18' 8") Boom; 2.00 m (6' 7") arm equipped with 0.92 m<sup>3</sup> (SAE heaped) bucket and 600 mm (24") triple grouser shoes.

Load point height m (ft)		Load radius						At max. reach				
		3.0 m (10 ft)		4.5 m (15 ft)		6.0 m (20 ft)		7.5 m (25 ft)		Capacity	Reach	
												m (ft)
7.5 m (25 ft)	kg lb									*3970 *8750	*3970 *8750	6.65 (21.8)
6.0 m (20 ft)	kg lb									*4400 *9700	*4400 *9700	7.78 (25.5)
4.5 m (15 ft)	kg lb									*5690 *12540	*5690 *12540	8.43 (27.7)
3.0 m (10 ft)	kg lb									*7420 *16360	*7420 *16360	8.74 (28.7)
1.5 m (5 ft)	kg lb									*8940 *19710	8430 18580	8.73 (28.6)
Ground Line	kg lb									*9640 *21250	8190 18060	8.42 (27.6)
-1.5 m (-5 ft)	kg lb	*13940 *30730	*13940 *30730	*9580 *21120	8160 17990	*6950 *15320	5190 11440			*4840 *10670	3630 8000	7.76 (25.5)
-3.0 m (-10 ft)	kg lb	*12450 *27450	*12450 *27450	*8770 *19330	8290 18280	*6310 *13910	5290 11660			*4800 *10580	4780 10540	6.61 (21.7)
-4.5 m (-15 ft)	kg lb	*9410 *20750	*9410 *20750									

5.68 m (18' 8") Boom; 2.40 m (7' 10") arm equipped with 0.92 m<sup>3</sup> (SAE heaped) bucket and 600 mm (24") triple grouser shoes.

Load point height m (ft)		Load radius						At max. reach					
		1.5 m (5 ft)		3.0 m (10 ft)		4.5 m (15 ft)		6.0 m (20 ft)		7.5 m (25 ft)		Capacity	Reach
7.5 m (25 ft)	kg lb												
6.0 m (20 ft)	kg lb												
4.5 m (15 ft)	kg lb												
3.0 m (10 ft)	kg lb												
1.5 m (5 ft)	kg lb												
Ground Line	kg lb												
-1.5 m (-5 ft)	kg lb	*9800 *21610	*9800 *21610	*13550 *29870	*13550 *29870	*9610 *21190	8090 17840	*6920 *15260	5140 11330				
-3.0 m (-10 ft)	kg lb	*14180 *31260	*14180 *31260	*13180 *29060	*13180 *29060	*9040 *19930	8170 18010	*6540 *14420	5190 11440				
-4.5 m (-15 ft)	kg lb												

- Lifting capacity are based on SAE J1097 and ISO 10567.
- Lifting capacity of the HX series does not exceed 75% of tipping load with the machine on firm, level ground or 87% of full hydraulic capacity.
- The load point is a hook located on the back of the bucket.
- (\*) indicates load limited by hydraulic capacity.

# LIFTING CAPACITY

Rating over-front Rating over-side or 360 degrees

## HX220 L HIGH WALKER

5.68 m (18' 8") Boom; 2.92 m (9' 7") arm equipped with 0.92 m<sup>3</sup> (SAE heaped) bucket and 600 mm (24") triple grouser shoes.

Load point height m (ft)	Load radius										At max. reach			
	1.5 m (5 ft)		3.0 m (10 ft)		4.5 m (15 ft)		6.0 m (20 ft)		7.5 m (25 ft)		Capacity	Reach		
7.5 m (25 ft)	kg										*3310	*3310	7.78	
	lb										*7300	*7300	(25.5)	
6.0 m (20 ft)	kg										*2300	*2300	8.74	
	lb										*5070	*5070	(28.7)	
4.5 m (15 ft)	kg					*3970	*3970	*3780	*3780	*3530	2780	9.32		
	lb					*8750	*8750	*8330	*8330	*7780	6130	(30.6)		
3.0 m (10 ft)	kg		*9720	*9720	*6100	*6100	*4790	*4790	*4180	3970	*3680	2580	9.59	
	lb		*21430	*21430	*13450	*13450	*10560	*10560	*9220	8750	*8110	5690	(31.5)	
1.5 m (5 ft)	kg		*8850	*8850	*7900	*7900	*5700	5450	*4660	3800	3660	2530	9.59	
	lb		*19510	*19510	*17420	*17420	*12570	12020	*10270	8380	8070	5580	(31.5)	
Ground Line	kg		*9590	*9590	*9100	8180	*6440	5210	*5060	3670	3810	2630	9.31	
	lb		*21140	*21140	*20060	18030	*14200	11490	*11160	8090	8400	5800	(30.5)	
-1.5 m (-5 ft)	kg	*8840	*8840	*12650	*12650	*9540	8010	*6810	5080	5240	3610	4230	2930	8.72
	lb	*19490	*19490	*27890	*27890	*21030	17660	*15010	11200	11550	7960	9330	6460	(28.6)
-3.0 m (-10 ft)	kg	*12230	*12230	*13910	*13910	*9260	8040	*6690	5080			*4420	3590	7.75
	lb	*26960	*26960	*30670	*30670	*20410	17730	*14750	11200			*9740	7910	(25.4)
-4.5 m (-15 ft)	kg		*11800	*11800	*8060	*8060						*4280	*4280	6.16
	lb		*26010	*26010	*17770	*17770						*9440	*9440	(20.2)

5.68 m (18' 8") Boom; 3.90 m (12' 9") arm equipped with 0.92 m<sup>3</sup> (SAE heaped) bucket and 600 mm (24") triple grouser shoes.

Load point height m (ft)	Load radius										At max. reach					
	1.5 m (5 ft)		3.0 m (10 ft)		4.5 m (15 ft)		6.0 m (20 ft)		7.5 m (25 ft)		9.0 m (30 ft)		Capacity	Reach		
9.0 m (30 ft)	kg												*2700	*2700	7.66	
	lb												*5950	*5950	(25.1)	
7.5 m (25 ft)	kg							*1940	*1940				*2760	*2760	8.94	
	lb							*4280	*4280				*6080	*6080	29.3	
6.0 m (20 ft)	kg							*2790	*2790				*2850	2600	9.77	
	lb							*6150	*6150				*6280	5730	(32.1)	
4.5 m (15 ft)	kg							*3050	*3050	*2000	*2000	*2970	2300	10.28		
	lb							*6720	*6720	*4410	*4410	*6550	5070	(33.7)		
3.0 m (10 ft)	kg						*3900	*3900	*3510	*3510	*2870	2860	*3110	2140	10.52	
	lb						*8600	*8600	*7740	*7740	*6330	6310	*6860	4720	(34.5)	
1.5 m (5 ft)	kg		*11080	*11080	*6600	*6600	*4900	*4900	*4080	3820	*3410	2760	3080	2090	10.52	
	lb		*24430	*24430	*14550	*14550	*10800	*10800	*8990	8420	*7520	6080	6790	4610	(34.5)	
Ground Line	kg	*5300	*5300	*10640	*10640	*8200	*8200	*5820	5210	*4610	3630	*3490	2660	3180	2150	10.27
	lb	*11680	*11680	*23460	*23460	*18080	*18080	*12830	11490	*10160	8000	*7690	5860	7010	4740	(33.7)
-1.5 m (-5 ft)	kg	*7540	*7540	*11690	*11690	*9110	7900	*6440	4990	*4990	3510	*2330	*2330	3450	2340	9.75
	lb	*16620	*16620	*25770	*25770	*20080	17420	*14200	11000	*11000	7740	*5140	*5140	7610	5160	(32.0)
-3.0 m (-10 ft)	kg	*10030	*10030	*14390	*14390	*9320	7800	*6660	4910	*5070	3470			*3850	2750	8.91
	lb	*22110	*22110	*31720	*31720	*20550	17200	*14680	10820	*11180	7650			*8490	6060	29.2
-4.5 m (-15 ft)	kg	*13000	*13000	*13310	*13310	*8780	7890	*6290	4960					*3990	3640	7.62
	lb	*28660	*28660	*29340	*29340	*19360	17390	*13870	10930					*8800	8020	(25.0)
-6.0 m (-20 ft)	kg		*10560	*10560	*7050	*7050										
	lb		*23280	*23280	*15540	*15540										

- Lifting capacity are based on SAE J1097 and ISO 10567.
- Lifting capacity of the HX series does not exceed 75% of tipping load with the machine on firm, level ground or 87% of full hydraulic capacity.
- The load point is a hook located on the back of the bucket.
- (\*) indicates load limited by hydraulic capacity.

# LIFTING CAPACITY

Rating over-front Rating over-side or 360 degrees

## HX220 NL

5.65 m (18' 6") Boom; 2.00 m (6' 7") arm equipped with 0.87 m<sup>3</sup> (SAE heaped) bucket and 500 mm (20") triple grouser shoes.

Load point height m (ft)	Load radius										At max. reach			
	3.0 m (10 ft)		4.5 m (15 ft)		6.0 m (20 ft)		7.5 m (25 ft)		Capacity	Reach				
7.5 m (25 ft)	kg										*4000	3810	6.61	
	lb										*8820	8400	(21.7)	
6.0 m (20 ft)	kg							*4420	4380			*4060	2800	7.75
	lb							*9740	9660			*8950	6170	(25.4)
4.5 m (15 ft)	kg							*5670	*5670	*4840	4230	*4200	2340	8.41
	lb							*12500	*12500	*10670	9330	*9260	5160	(27.6)
3.0 m (10 ft)	kg							*7430	6170	*5600	3990	*4360	2130	8.71
	lb							*16380	13600	*12350	8800	*10650	4700	(28.6)
1.5 m (5 ft)	kg							*8990	5700	*6390	3760	*5190	2640	8.71
	lb							*19820	12570	*14090	8290	*11440	5820	(28.6)
Ground Line	kg							*9720	5490	*6930	3610	5380	2570	8.40
	lb							*21430	12100	*15280	7960	11860	5670	(27.6)
-1.5 m (-5 ft)	kg	*14170	10580	*9690	5460	*7030	3560					*4930	2540	7.73
	lb	*31240	23320	*21360	12040	*15500	7850					*10870	5600	(25.4)
-3.0 m (-10 ft)	kg	*12680	10790	*8900	5570	*6390	3650					*4910	3380	6.58
	lb	*27950	23790	*19620	12280	*14090	8050					*10820	7450	(21.6)

5.65 m (18' 6") Boom; 2.00 m (6' 7") arm equipped with 0.87 m<sup>3</sup> (SAE heaped) bucket and 500 mm (20") triple grouser shoes.

Load point height m (ft)	Load radius										At max. reach					
	1.5 m (5 ft)		3.0 m (10 ft)		4.5 m (15 ft)		6.0 m (20 ft)		7.5 m (25 ft)		Capacity	Reach				
7.5 m (25 ft)	kg											*3690	3360	7.12		
	lb											*8140	7410	(23.4)		
6.0 m (20 ft)	kg							*3990	*3990			*3780	2540	8.18		
	lb							*8800	*8800			*8330	5600	(26.8)		
4.5 m (15 ft)	kg							*4460	4280	*4050	2860	*3910	2140	8.80		
	lb							*9830	9440	*8930	6310	*8620	4720	(28.9)		
3.0 m (10 ft)	kg							*6850	6280	*5260	4020	*4560	2760	*4080	1950	9.09
	lb							*15100	13850	*11600	8860	*10050	6080	*8990	4300	(29.8)
1.5 m (5 ft)	kg							*8540	5750	*6120	3760	*4980	2630	4030	1910	9.08
	lb							*18830	12680	*13490	8290	*10980	5800	8880	4210	(29.8)
Ground Line	kg							*9080	*9080	*9520	5470	*6760	3580	*5310	2540	8.79
	lb							*20020	*20020	*20990	12060	*14900	7890	*11710	5600	(28.8)
-1.5 m (-5 ft)	kg	*9930	*9930	*13780	10400	*9710	5400	*6990	3510					*4670	2280	8.16
	lb	*21890	*21890	*30380	22930	*21410	11900	*15410	7740					*10300	5030	(26.8)
-3.0 m (-10 ft)	kg	*14320	*14320	*13400	10600	*9170	5470	*6630	3550					*4750	2940	7.09
	lb	*31570	*31570	*29540	23370	*20220	12060	*14620	7830					*10470	6480	(23.3)
-4.5 m (-15 ft)	kg							*10790	*10790	*7470	5710					
	lb							*23790	*23790	*16470	12590					

- Lifting capacity are based on SAE J1097 and ISO 10567.
- Lifting capacity of the HX series does not exceed 75% of tipping load with the machine on firm, level ground or 87% of full hydraulic capacity.
- The load point is a hook located on the back of the bucket.
- (\*) indicates load limited by hydraulic capacity.



# LIFTING CAPACITY

Rating over-front Rating over-side or 360 degrees

## HX220 NL

5.65 m (18' 6") Boom; 2.92 m (9' 7") arm equipped with 0.87 m<sup>3</sup> (SAE heaped) bucket and 500 mm (20") triple grouser shoes.

Load point height m (ft)	Load radius								At max. reach					
	1.5 m (5 ft)		3.0 m (10 ft)		4.5 m (15 ft)		6.0 m (20 ft)		7.5 m (25 ft)		Capacity	Reach		
											kg (lb)	m (ft)		
7.5 m (25 ft)	kg										*3350	2890	7.76	
	lb										*7390	6370	(25.5)	
6.0 m (20 ft)	kg							*2140	*2140	*3440	2250	8.73		
	lb							*4720	*4720	*7580	4960	(28.6)		
4.5 m (15 ft)	kg					*3970	*3970	*3810	2900	*3580	1920	9.30		
	lb					*8750	*8750	*8400	6390	*7890	4230	(30.5)		
3.0 m (10 ft)	kg		*9630	*9630	*6090	*6090	*4810	4060	*4210	2770	3730	1750	9.58	
	lb		*21230	*21230	*13430	*13430	*10600	8950	*9280	6110	8220	3860	(31.4)	
1.5 m (5 ft)	kg		*9210	*9210	*7920	5830	*5730	3780	*4700	2630	3680	1710	9.57	
	lb		*20300	*20300	*17460	12850	*12630	8330	*10360	5800	8110	3770	(31.4)	
Ground Line	kg		*9810	*9810	*9160	5460	*6490	3560	*5120	2510	3830	1780	9.29	
	lb		*21630	*21630	*20190	12040	*14310	7850	*11290	5530	8440	3920	(30.5)	
-1.5 m (-5 ft)	kg	*8950	*8950	*12850	10220	*9630	5320	*6880	3450	5250	2450	4250	2000	8.71
	lb	*19730	*19730	*28330	22530	*21230	11730	*15170	7610	11570	5400	9370	4410	(28.6)
-3.0 m (-10 ft)	kg	*12340	*12340	*14120	10360	*9380	5340	*6770	3450			*4490	2490	7.73
	lb	*27210	*27210	*31130	22840	*20680	11770	*14930	7610			*9900	5490	(25.4)
-4.5 m (-15 ft)	kg			*12010	10690	*8180	5510					*4360	3750	6.14
	lb			*26480	23570	*18030	12150					*9610	8270	(20.1)

## HX220 NL 2-PIECE BOOM

5.65 m (18' 6") 2-Piece Boom; 2.00 m (6' 7") arm equipped with 0.87 m<sup>3</sup> (SAE heaped) bucket and 500 mm (20") triple grouser shoes.

Load point height m (ft)	Load radius								At max. reach			
	3.0 m (10 ft)		4.5 m (15 ft)		6.0 m (20 ft)		7.5 m (25 ft)		Capacity	Reach		
									kg (lb)	m (ft)		
10.5 m (35 ft)	kg								*6200	*6200	4.64	
	lb								*13670	*13670	(15.2)	
9.0 m (30 ft)	kg								*6560	*6560	4.60	
	lb								*14460	*14460	(15.1)	
7.5 m (25 ft)	kg			*6750	*6750				*5330	3710	6.66	
	lb			*14880	*14880				*11750	8180	(21.9)	
6.0 m (20 ft)	kg			*6910	*6910	*5910	4340		*4920	2720	7.79	
	lb			*15230	*15230	*13030	9570		*10850	6000	(25.6)	
4.5 m (15 ft)	kg	*11400	*11400	*7810	6710	*6200	4190		4680	2270	8.45	
	lb	*25130	*25130	*17220	14790	*13670	9240		10320	5000	(27.7)	
3.0 m (10 ft)	kg			*9020	6090	*6670	3930	*5380	2700	4350	2060	8.75
	lb			*19890	13430	*14700	8660	*11860	5950	9590	4540	(28.7)
1.5 m (5 ft)	kg			*9720	5600	*6990	3690	*5410	2590	4300	2020	8.75
	lb			*21430	12350	*15410	8140	*11930	5710	9480	4450	(28.7)
Ground Line	kg			*9430	5390	*6900	3540	*5130	2520	*4020	2140	8.43
	lb			*20790	11880	*15210	7800	*11310	5560	*8860	4720	(27.7)
-1.5 m (-5 ft)	kg	*10050	*10050	*8270	5380	*6170	3500			*3440	2490	7.77
	lb	*22160	*22160	*18230	11860	*13600	7720			*7580	5490	(25.5)
-3.0 m (-10 ft)	kg			*6160	5520	*4350	3610					
	lb			*13580	12170	*9590	7960					

1. Lifting capacity are based on SAE J1097 and ISO 10567.  
2. Lifting capacity of the HX series does not exceed 75% of tipping load with the machine on firm, level ground or 87% of full hydraulic capacity.

3. The load point is a hook located on the back of the bucket.  
4. (\*) indicates load limited by hydraulic capacity.

# LIFTING CAPACITY

Rating over-front Rating over-side or 360 degrees

## HX220 NL 2-PIECE BOOM

5.65 m (18' 6") 2-Piece Boom; 2.40 m (7' 10") arm equipped with 0.87 m<sup>3</sup> (SAE heaped) bucket and 500 mm (20") triple grouser shoes.

Load point height m (ft)	Load radius								At max. reach			
	3.0 m (10 ft)		4.5 m (15 ft)		6.0 m (20 ft)		7.5 m (25 ft)		Capacity	Reach		
									kg (lb)	m (ft)		
9.0 m (30 ft)	kg									*5730	5470	5.39
	lb									*12630	12060	(17.7)
7.5 m (25 ft)	kg			*5870	*5870					*4900	3260	7.18
	lb			*12940	*12940					*10800	7190	(23.6)
6.0 m (20 ft)	kg			*6440	*6440	*5570	4420			*4570	2460	8.23
	lb			*14200	*14200	*12280	9740			*10080	5420	(27.0)
4.5 m (15 ft)	kg	*10330	*10330	*7350	6840	*5920	4240	*4360	2820	4330	2070	8.84
	lb	*22770	*22770	*16200	15080	*13050	9350	*9610	6220	9550	4560	(29.0)
3.0 m (10 ft)	kg			*8630	6210	*6450	3960	*5240	2710	4040	1890	9.13
	lb			*19030	13690	*14220	8730	*11550	5970	8910	4170	(30.0)
1.5 m (5 ft)	kg			*9550	5650	*6870	3700	*5360	2580	3990	1850	9.13
	lb			*21050	12460	*15150	8160	*11820	5690	8800	4080	(30.0)
Ground Line	kg	*8600	*8600	*9560	5370	*6920	3510	*5230	2490	*3840	1950	8.83
	lb	*18960	*18960	*21080	11840	*15260	7740	*11530	5490	*8470	4300	(29.0)
-1.5 m (-5 ft)	kg	*11450	10280	*8660	5310	*6390	3450	*4540	2470	*3390	2230	2.21
	lb	*25240	22660	*19090	11710	*14090	7610	*10010	5450	*7470	4920	(26.9)
-3.0 m (-10 ft)	kg			*6840	5400	*4980	3510					
	lb			*15080	11900	*10980	7740					

5.65 m (18' 6") 2-Piece Boom; 2.92 m (9' 7") arm equipped with 0.87 m<sup>3</sup> (SAE heaped) bucket and 500 mm (20") triple grouser shoes.

Load point height m (ft)	Load radius								At max. reach			
	3.0 m (10 ft)		4.5 m (15 ft)		6.0 m (20 ft)		7.5 m (25 ft)		Capacity	Reach		
									kg (lb)	m (ft)		
9.0 m (30 ft)	kg			*3290	*3290					*4600	4260	6.28
	lb			*7250	*7250					*10140	9390	(20.6)
7.5 m (25 ft)	kg					*3530	*3530			*4030	2800	7.83
	lb					*7780	*7780			*8880	6170	(25.7)
6.0 m (20 ft)	kg			*5170	*5170	*4870	4510	*2440	*2440	*3800	2170	8.78
	lb			*11400	*11400	*10740	9940	*5380	*5380	*8380	4780	(28.8)
4.5 m (15 ft)	kg			*6720	*6720	*5540	4310	*4390	2860	*3740	1850	9.36
	lb			*14820	*14820	*12210	9500	*9680	6310	*8250	4080	(30.7)
3.0 m (10 ft)	kg	*12710	12080	*8080	6370	*6130	4020	*5040	2720	3690	1690	9.63
	lb	*28020	26630	*17810	14040	*13510	8860	*11110	6000	8140	3730	(31.6)
1.5 m (5 ft)	kg	*8700	*8700	*9240	5740	*6660	3720	*5240	2570	3640	1650	9.63
	lb	*19180	*19180	*20370	12650	*14680	8200	*11550	5670	8020	3640	(31.6)
Ground Line	kg	*9390	*9390	*9580	5360	*6880	3490	*5260	2450	*3610	1720	9.35
	lb	*20700	*20700	*21120	11820	*15170	7690	*11600	5400	*7960	3790	(30.7)
-1.5 m (-5 ft)	kg	*12500	10070	*9020	5230	*6570	3380	*4860	2400	*3270	1950	8.77
	lb	*27560	22200	*19890	11530	*14480	7450	*10710	5290	*7210	4300	(28.8)
-3.0 m (-10 ft)	kg	*10150	*10150	*7560	5270	*5530	3400					
	lb	*22380	*22380	*16670	11620	*12190	7500					

1. Lifting capacity are based on SAE J1097 and ISO 10567.  
2. Lifting capacity of the HX series does not exceed 75% of tipping load with the machine on firm, level ground or 87% of full hydraulic capacity.

3. The load point is a hook located on the back of the bucket.  
4. (\*) indicates load limited by hydraulic capacity.

# SPECIFICATIONS

## HX220 L

ENGINE	STD	OPT
Cummins QSB 6.7 engine	●	
<b>HYDRAULIC SYSTEM</b>		
<b>Intelligent Power Control (IPC)</b>		
3-power mode, 2-work mode, user mode	●	
Variable Power Control	●	
Pump Flow Control	●	
Attachment Mode Flow Control		●
Engine Auto Idle	●	
Engine Auto Shutdown Control		●
Electronic Fan Control	●	
<b>CABIN &amp; INTERIOR</b>		
<b>ISO Standard cabin</b>		
Rise-up type windshield wiper	●	
Radio / USB player	●	
Handsfree mobile phone system with USB	●	
12 volt power outlet (24V DC to 12V DC converter)	●	
Electric horn	●	
All-weather steel cab with 360° visibility	●	
Safety glass windows	●	
Sliding fold-in front window	●	
Sliding side window (LH)	●	
Lockable door	●	
Hot & cool box	●	
Storage compartment & Ashtray	●	
Transparent cabin roof-cover	●	
Sun visor	●	
Door and cab locks, one key	●	
Mechanical suspension seat with heater	●	
Pilot-operated slidable joystick	●	
Console box height adjust system	●	
<b>Automatic climate control</b>		
Air conditioner & heater	●	
Defroster	●	
Starting Aid (air grid heater) for cold weather	●	
<b>Centralized monitoring</b>		
8" LCD display	●	
Engine speed or Trip meter/Accel.	●	
Engine coolant temperature gauge	●	
Max power	●	
Low speed/High speed	●	
Auto idle	●	
Overload	●	
Check Engine	●	
Air cleaner clogging	●	
Indicators	●	
ECO Gauges	●	
Fuel level gauge	●	
Hyd. oil temperature gauge	●	
Fuel warmer	●	
Warnings	●	
Communication error	●	
Low battery	●	
Clock	●	
Cabin lights		●
Cabin front window rain guard		●
Cabin roof-steel cover		●
<b>Seat</b>		
Adjustable air suspension seat with heater		●
<b>Cabin FOPS/FOG (ISO/DIS 10262) Level 2</b>		
FOPS (Falling Object Protective Structure) · ISO 3449 Level 2		●
FOG (Falling Object Guard)		●
<b>Cabin ROPS (ISO 12117-2)</b>		
ROPS (Roll Over Protective Structure)	●	

SAFETY	STD	OPT
Battery master switch	●	
Rearview camera	●	
AAVM (Advanced Around View Monitoring)		●
Four front working lights	●	
Travel alarm	●	
Rear work lamp		●
Beacon lamp		●
Automatic swing brake	●	
Boom holding system	●	
Arm holding system	●	
Safety lock valve for boom cylinder with overload warning device	●	
Safety lock valve for arm cylinder		●
Swing Lock System		●
Three outside rearview mirrors	●	
<b>OTHER</b>		
<b>Booms</b>		
5.68 m; 18' 8" Mono boom	●	
5.65 m; 18' 6" 2-Piece boom		●
8.2 m; 26' 11" Long reach		●
<b>Arms</b>		
2.0 m; 6' 7"		●
2.4 m; 7' 10"		●
2.92 m; 9' 7"	●	
3.9 m; 12' 10"		●
6.3 m; 20' 8" Long reach		●
Removable clean-out dust net for cooler	●	
Removable reservoir tank	●	
Fuel pre-filter	●	
Fuel warmer	●	
Self-diagnostics system	●	
Hi MATE (Remote Management System)	●	
Batteries (2 x 12 V x 100 Ah)	●	
Fuel filler pump (50 l/min)	●	
Single-acting piping kit (breaker, etc.)		●
Double-acting piping kit (clamshell, etc.)	●	
Rotating Piping Kit		●
Quick coupler piping		●
Quick coupler		●
Boom floating control		●
One Pedal Straight Travel System		●
Accumulator for lowering work equipment	●	
Pattern change valve (2 patterns)		●
Fine Swing Control System		●
Tool kit		●
<b>UNDERCARRIAGE</b>		
Lower frame under cover (Additional)		●
Lower frame under cover (Normal)	●	
<b>Track shoes</b>		
Triple grouser shoes (600 mm; 24")	●	
Triple grouser shoes (700 mm; 28")		●
Triple grouser shoes (800 mm; 32")		●
Triple grouser shoes (900 mm; 36")		●
Double grouser shoes (600 mm; 24")		●
Double grouser shoes (700 mm; 28")		●
Track rail guard	●	
Full track rail guard high walker		●

STD = Standard  
OPT = Optional

# SPECIFICATIONS

## HX220 NL

ENGINE	STD	OPT
Cummins QSB 6.7 engine	●	
<b>HYDRAULIC SYSTEM</b>		
<b>Intelligent Power Control (IPC)</b>		
3-power mode, 2-work mode, user mode	●	
Variable Power Control	●	
Pump Flow Control	●	
Attachment Mode Flow Control		●
Engine Auto Idle	●	
Engine Auto Shutdown Control		●
Electronic Fan Control	●	
<b>CABIN &amp; INTERIOR</b>		
<b>ISO Standard cabin</b>		
Rise-up type windshield wiper	●	
Radio / USB player	●	
Handsfree mobile phone system with USB	●	
12 volt power outlet (24V DC to 12V DC converter)	●	
Electric horn	●	
All-weather steel cab with 360° visibility	●	
Safety glass windows	●	
Sliding fold-in front window	●	
Sliding side window (LH)	●	
Lockable door	●	
Hot & cool box	●	
Storage compartment & Ashtray	●	
Transparent cabin roof-cover	●	
Sun visor	●	
Door and cab locks, one key	●	
Mechanical suspension seat with heater	●	
Pilot-operated slidable joystick	●	
Console box height adjust system	●	
<b>Automatic climate control</b>		
Air conditioner & heater	●	
Defroster	●	
Starting Aid (air grid heater) for cold weather	●	
<b>Centralized monitoring</b>		
8" LCD display	●	
Engine speed or Trip meter/Accel.	●	
Engine coolant temperature gauge	●	
Max power	●	
Low speed/High speed	●	
Auto idle	●	
Overload	●	
Check Engine	●	
Air cleaner clogging	●	
Indicators	●	
ECO Gauges	●	
Fuel level gauge	●	
Hyd. oil temperature gauge	●	
Fuel warmer	●	
Warnings	●	
Communication error	●	
Low battery	●	
Clock	●	
Cabin lights		●
Cabin front window rain guard		●
Cabin roof-steel cover		●
<b>Seat</b>		
Adjustable air suspension seat with heater		●
<b>Cabin FOPS/FOG (ISO/DIS 10262) Level 2</b>		
FOPS (Falling Object Protective Structure) · ISO 3449 Level 2		●
FOG (Falling Object Guard)		●
<b>Cabin ROPS (ISO 12117-2)</b>		
ROPS (Roll Over Protective Structure)	●	

SAFETY	STD	OPT
Battery master switch	●	
Rearview camera	●	
AAVM (Advanced Around View Monitoring)		●
Four front working lights	●	
Travel alarm	●	
Rear work lamp		●
Beacon lamp		●
Automatic swing brake	●	
Boom holding system	●	
Arm holding system	●	
Safety lock valve for boom cylinder with overload warning device	●	
Safety lock valve for arm cylinder		●
Swing Lock System		●
Three outside rearview mirrors	●	
<b>OTHER</b>		
<b>Booms</b>		
5.65 m; 18' 6" Mono boom	●	
5.65 m; 18' 6" 2-Piece boom		●
<b>Arms</b>		
2.0 m; 6' 7"		●
2.4 m; 7' 10"		●
2.92 m; 9' 7"	●	
Removable clean-out dust net for cooler	●	
Removable reservoir tank	●	
Fuel pre-filter	●	
Fuel single warmer	●	
Fuel dual warmer		●
Self-diagnostics system	●	
Hi MATE (Remote Management System)	●	
Batteries (2 x 12 V x 100 Ah)	●	
Fuel filler pump (50 l/min)	●	
Single-acting piping kit (breaker, etc.)		●
Double-acting piping kit (clamshell, etc.)	●	
Rotating Piping Kit		●
Quick coupler piping		●
Quick coupler		●
One Pedal Straight Travel System		●
Accumulator for lowering work equipment	●	
Pattern change valve (2 patterns)		●
Fine Swing Control System		●
Tool kit		●
<b>UNDERCARRIAGE</b>		
Lower frame under cover (Additional)		●
Lower frame under cover (Normal)	●	
<b>Track shoes</b>		
Triple grouser shoes (600 mm; 24")	●	
Triple grouser shoes (700 mm; 28")		●
Triple grouser shoes (800 mm; 32")		●
Triple grouser shoes (900 mm; 36")		●
Double grouser shoes (600 mm; 24")		●
Double grouser shoes (700 mm; 28")		●
Track rail guard	●	
Full track rail guard		●

STD = Standard  
OPT = Optional



- \* Standard and optional equipment may vary. Contact your Hyundai dealer for more information.  
The machine may vary according to International standards.
- \* The photos may include attachments and optional equipment that are not available in your area.
- \* Materials and specifications are subject to change without advance notice.
- \* All imperial measurements rounded off to the nearest pound or inch.
- \* The air conditioning system on this machine contains the fluorinated greenhouse gas refrigerant HFC-134a (Global Warming Potential = 1430).  
The system contains 0.65 kg of refrigerant which has a CO<sub>2</sub> equivalent of 0.9295 metric tonne.

---

 **HYUNDAI CONSTRUCTION EQUIPMENT**

PLEASE CONTACT

**Hyundai Construction Equipment Europe nv**

Hyundailaan 4, 3980 Tessenderlo, Belgium **Tel:** (32) 14-56-2200 **Fax:** (32) 14-59-3405

[www.hyundai.eu](http://www.hyundai.eu)

EN - 2017.11 Rev 5

---