

Product Description



Model No.: WT100

- 1 Mirror surface LCD touch display screen with brightness adjustable backlight.
- 2 Official Tuya wifi module build in.
- 3 APP remote control
- 4 Voice control via amazon alexa, google home, Yandex Alice ect.
- 5 Weekly programmable, 6 time period/ day on weekend, 2 time period/ day on week days.
- 6 Accuracy of temperature setting 0.5°C, detection display 0.1°C, hysteresis 0.5°C~ 10°C.



Specification

Type	Electric heating/Water&Boiler heating 2 in 1
Material	Anti-flammable PC
Voltage	AC 95-220V 50/60Hz
Max. Current Load	16A/3A
Temperature Accuracy	±1°C
Temperature Setting	5°C-90°C
Key Type	Touch Key
Item Size	86 * 86 * 40mm / 3.4 * 3.4 * 1.6in
APP	Smart Life/Tuya Smart
Voice Control	Amazon Alexa,Google Home,Yandex Alice ect
Protocol	Wifi 2.4GHZ
Application	Suitable for electric heating/water gas boiler/water heating.Perfect for home, office, shopping mall, hotel, etc.



WiFi Thermostat

Touch button, classic design



APP Remote Control

Smart life app remote control from anywhere, anytime



Voice Control

Work with Alexa and Google home, Yandex Alice



"Alexa(or google home),
stell die Raumtemperatur auf 28.5°C"

"OK"



Weekly Programmable

5+2/6+1/7 days, supports different
temperature setting accordingly
with 6 time-modes daily

Backlight Brightness Adjustable

Backlight can be adjust and turn off, to avoid disturbing sleep

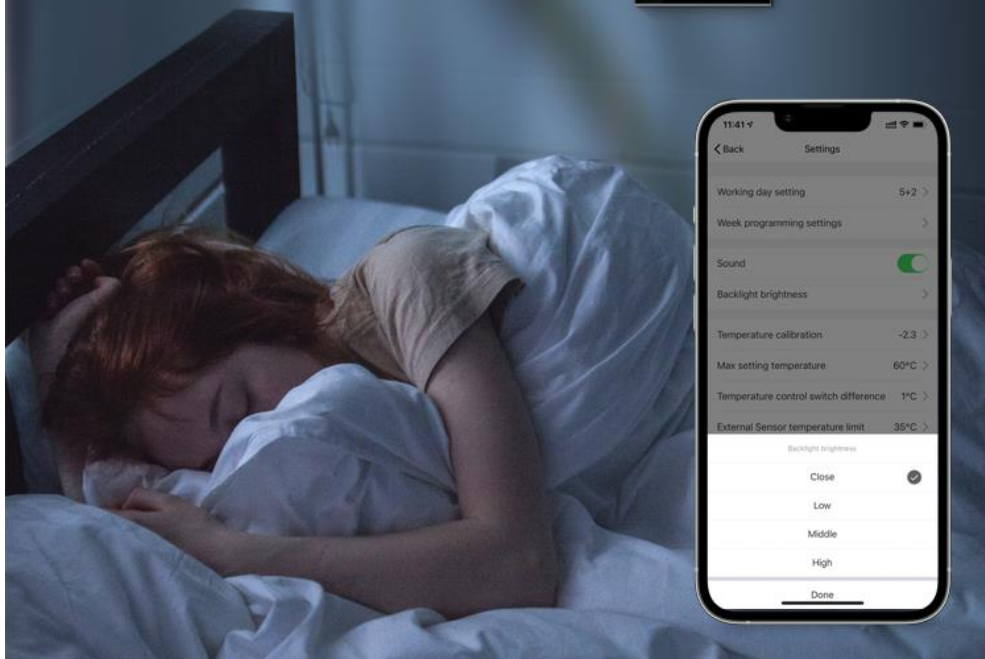

Precise temperature control, more comfortable

0.5~10°C

Temperature hysteresis

0.5°C

minimum temperature setting



Group-Control Function

Realize group control in different room in special scene

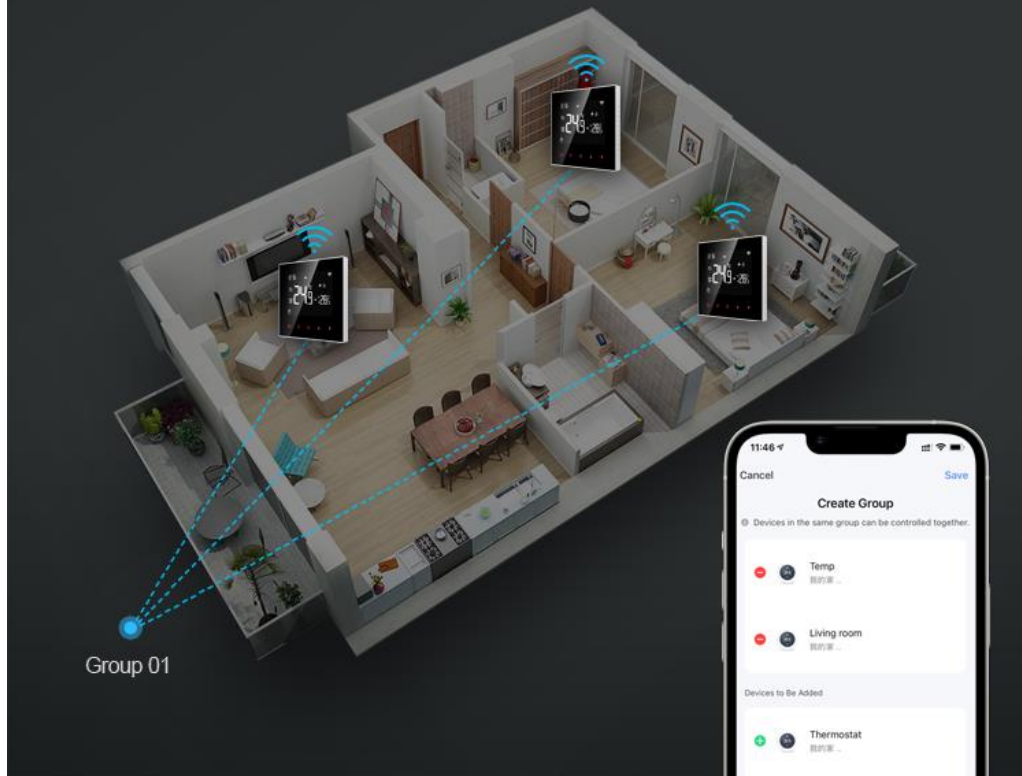

Children Lock

Locking function is designed to prevent children from operating by mistake



Water Heating 3A

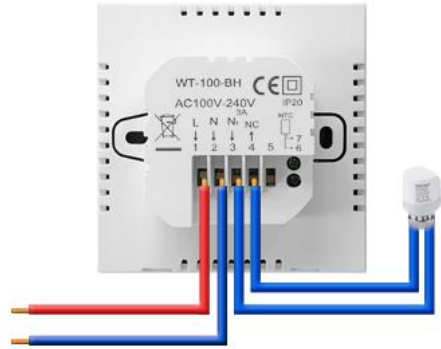
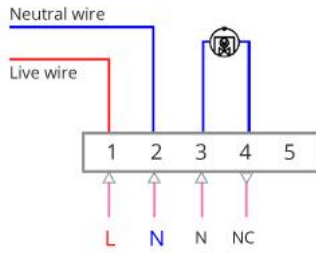

Switch NC \rightleftharpoons NO



Product Parameter



Electric Floor Heating 16A

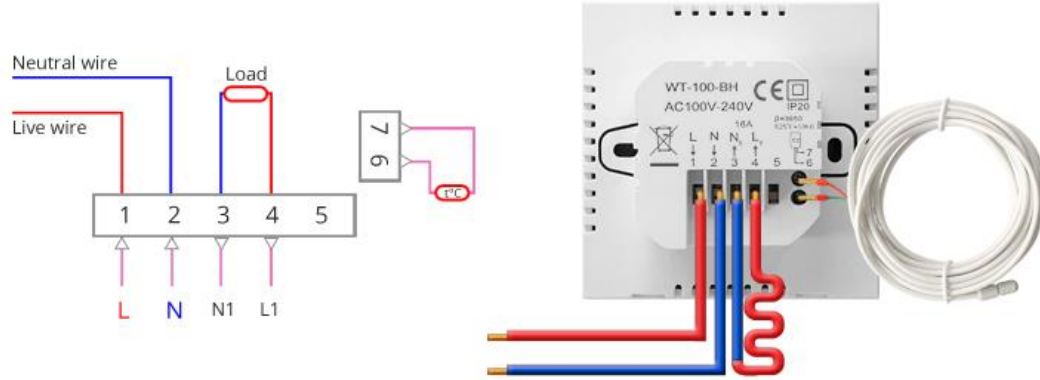

Water/Gas Boiler 3A

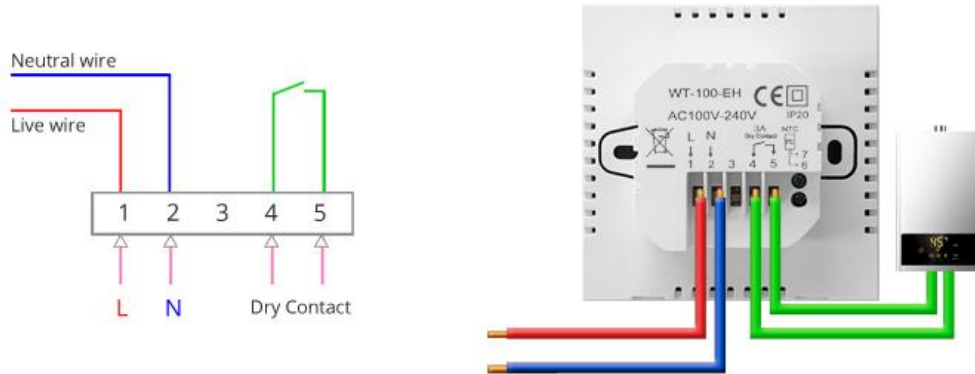

Packing&Shipping



Single Item Packing Date	
Electric Heating	Water Heating/Gas Boiler:
GW: 281.00g	GW: 219.80g
NW: 170.50g	NW: 173.20g
Quantity: 1 PCS/ Box	Quantity: 1 PCS/ Box
Package Size: 10.10x10.5x6.7 CM	Package Size: 10.10x10.5x6.7 CM

Carton Packing Date	
Electric Heating:	Water Heating/Gas Boiler
GW: 20.20 KG	GW: 16.11 KG
NW: 17.99 KG	NW: 11.08 KG
Quantity: 64 PCS/ Carton	Quantity: 64 PCS/ Carton
Carton Size: 42.5x41.5x30 CM	Carton Size: 42.5x41.5x30 CM

PACKAGE LIST					
	Thermostat	Packing box	instructions	Screws*2	External sensor (3m)
Electric Floor Heating 16A	✓	✓	✓	✓	✓
Water/Gas Boiler 3A	✓	✓	✓	✓	✗
Water Heating 3A	✓	✓	✓	✓	✗