



PHOENIX[®]
 DURABILITY X DESIGN™



Cube-Light

Compact LED Area Light

Australian Design No. 359170
 US Patent No. D762,321 S

Delivers up to 1000 lumens to doorways, walkways, cabins or other small areas

Competitive pricing with short lead times

Various mounting options for maximum versatility

LED technology increases efficiency, eliminates maintenance and supports green initiatives

Dimensions

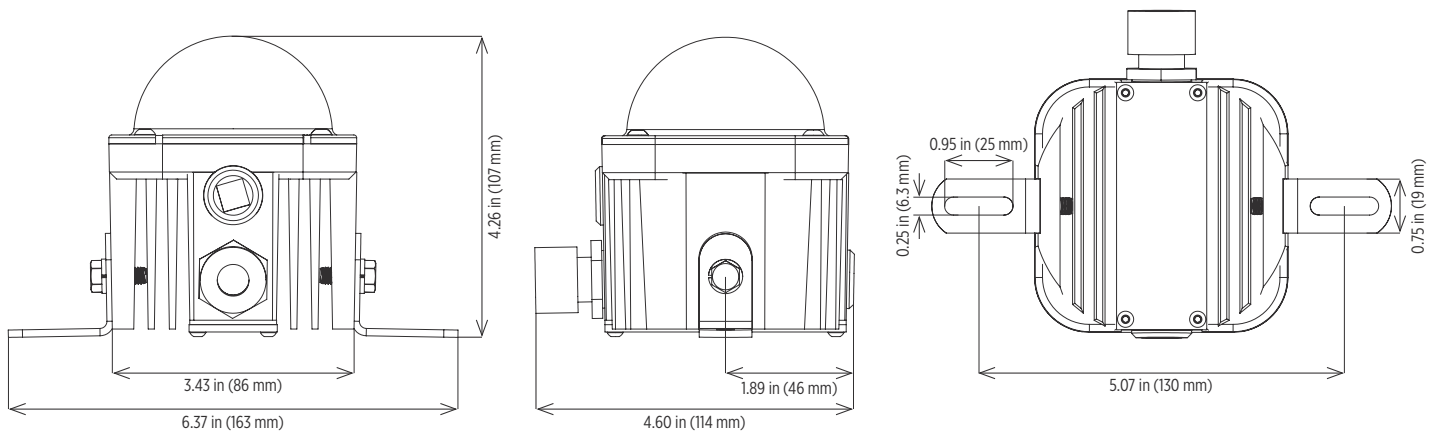

Cube-Light

Compact LED Area Light

Specifications

Construction	Cast aluminum housing
Finish	White thermoset powder coat
Hardware	Marine grade (316) stainless steel
Lens	Impact-resistant, diffuse polycarbonate Diffuse red, green, blue and amber lens accessories available (AMB-CL, BLU-CL, GRN-CL, RED-CL)
Light source	13W, up to 1000 lumens Conformal coated CRI ≥ 70 CCT 5000K 50,000 hour rated life
Power source	120-240V, 50/60Hz 240V, 50/60Hz 13-27V DC
Wiring	Stranded wires Cord not included - standard 72.00 inch (1829 mm) cord with pigtail option (CD) NEMA 5-15 plug (120V only) sold separately (PLG-515)
Through wiring	Continuous row mounting option (TW)
Ambient operating temperature	-30°C to +50°C
Mounting	Flush mount brackets - standard Harp mount available Rail mount available - 2.00 inch overall diameter Fixture can be mounted in any orientation
Weight	2.0 lb (0.9 kg)
Warranty	3 years

For IES files, see website or contact factory

Compliances

ETL/cETL Listed to:

- UL 1598 Suitable for Wet Locations
- UL 1598A Marine Outside Type (Saltwater)
- CSA C22.2 No. 250.0

CE

ABS

IP66 rated

LM79 and LM80 reports available



The Cube-Light on an STS crane



Ordering Information

Example: CL-13LED-120-240

Fixture	Wattage/Type	Voltage	Options
CL	13LED	120-240 ^{1,2} 240 ² DC ³	CD TW

Wattage/Type	Voltage	Options	Notes
13LED 13W, up to 1000 lumens	120-240 ^{1,2} 120-240V, 50/60Hz 240 ² 240V, 50/60Hz DC ³ 13-27V DC	CD 72.00 inch (1829 mm) cord with pigtail option TW Continuous row mounting	1 ETL/cETL listed 2 CE 3 No certifications

Special Projects: We may be able to accommodate your special projects, so please don't hesitate to ask about additional options. Minimum order quantities and/or extended lead times will apply. Contact your Phoenix representative with specific inquiries.

Mounting (order separately)

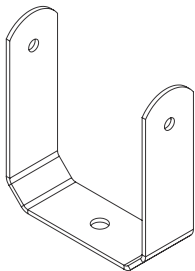

Harp Mount
HRP-CL

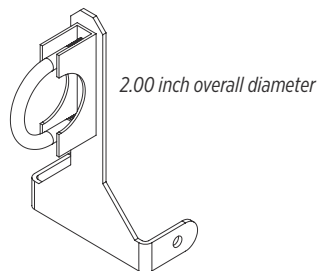

Rail Mount
RLMT-CL
Contact factory

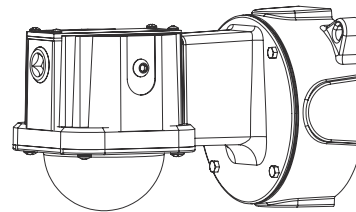

Wall Mount
Complete fixture sold separately
Refer to Cube-Light Wall Mount spec sheet

Flush mount comes standard with fixture

Accessories (order separately)

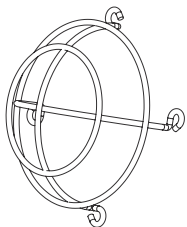

Wire Guard Kit
WG-CL

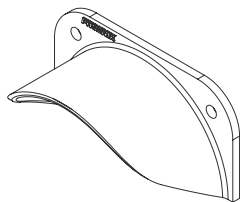

Visor Kit
VSR-CL

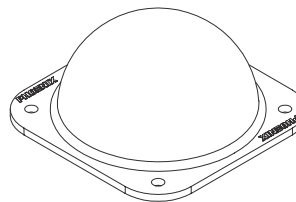

Color Lens Kits
AMB-CL amber lens kit
BLU-CL blue lens kit
GRN-CL green lens kit
RED-CL red lens kit

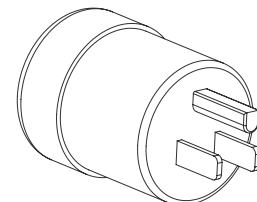

NEMA 5-15 plug (120V only)
PLG-515



Cube-Light

Compact LED Area Light

PHOENIX[®]
DURABILITY X DESIGN™

Cover photo: Cube-Light shown flush mounted along an accessway on a ship-to-shore crane

Product design and specifications are subject to change without notice. The most current version of this specification sheet can be found on our website: www.phoenixlighting.com.



Phoenix Products LLC 8711 West Port Avenue Milwaukee, WI 53224 USA
Phone: +1 414.973.3300 Toll Free: 800.438.1214 Fax: +1 414.973.3210 www.phoenixlighting.com

N5485010N
10.15.18